

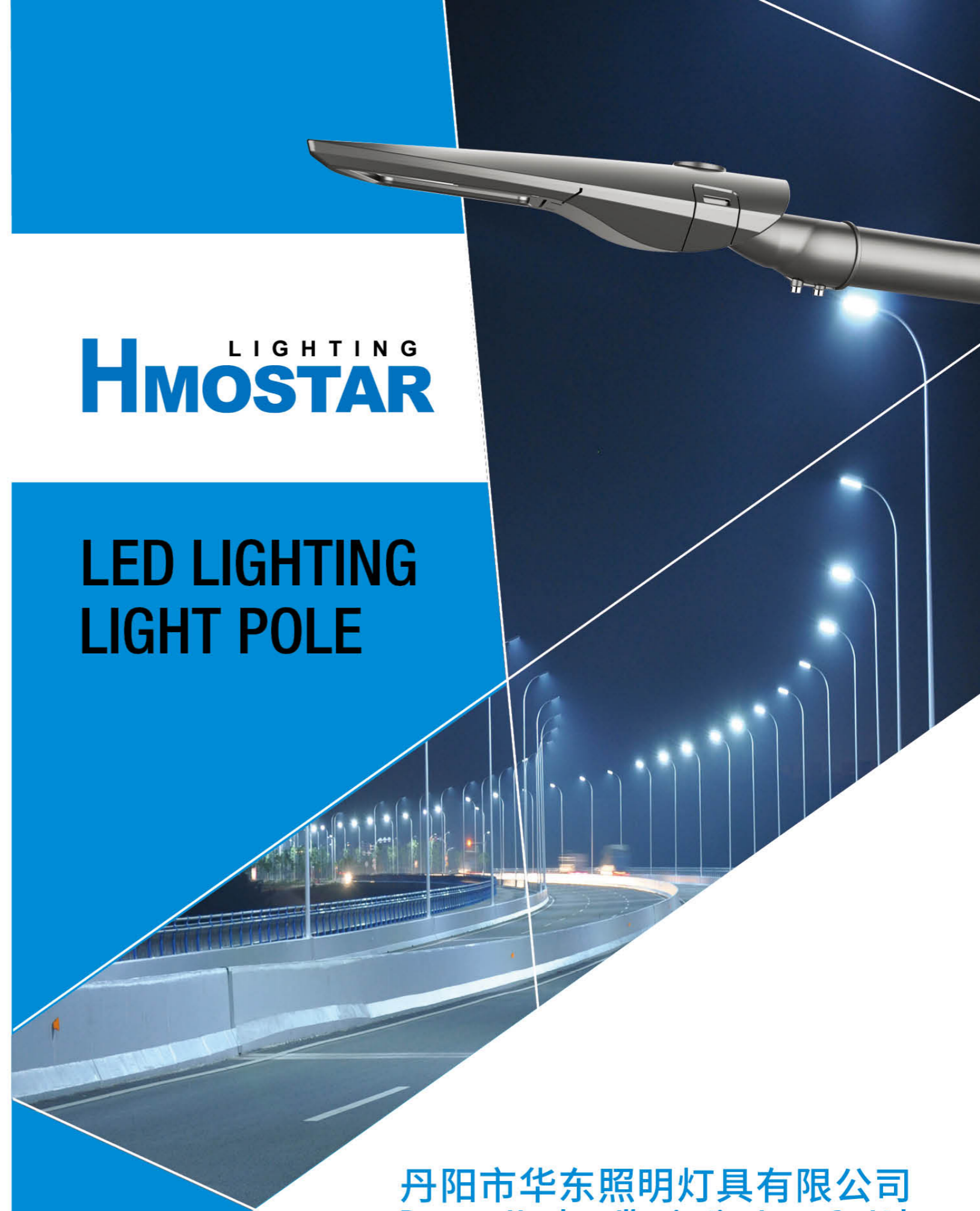

LIGHTING  
**HMOSTAR**

**LED LIGHTING  
LIGHT POLE**



**Danyang Huadong Illumination Lamp Co.,Ltd.**

Add: No.2, Lamp City Street, Jiepai Town, Danyang City,  
Jiangsu Province, China.

Tel: 0086 511 88011101

Fax: 0086 511 88011133

Http: //www.hmostar.com

E-mail: ellen@hmostar.com



**丹阳市华东照明灯具有限公司**

中国江苏省丹阳市界牌镇灯城大街北首

电话: +86 511 8801 9966 8801 1103

传真: +86 511 8801 1133

邮编: 212323

网址: www.hd-light.cn

邮箱: ellen@hmostar.com



**丹阳市华东照明灯具有限公司**  
Danyang Huadong Illumination Lamp Co.,Ltd.





## Company Profile

Hmostar founded in 1989 is located in Danyang City, Jiangsu province, China. Zhenjiang and Shanghai port are the nearest. Hmostar has two plants: new factory has 100,000m<sup>2</sup>; Another one has 23,500m<sup>2</sup>. It has more than 300 skilled employees and engineers and equipped our our laboratory.

Hmostar is a professional lighting manufacturer specialized in R&D, production, domestic and international sales of Light pole, HID / LED street light, LED garden light, LED flood light, LED high bay & High mast which are exported to more than 50 countries and regions in Asia, Europe, North America, South America, Middle east and Africa, etc.

### Testing Centre



Photometric Distribution Instrument



Integrating Sphere



High-low Temperature Testing



Salt Spraying Test Machine



Water-proof Class Testing System



Dust-proof Class Testing System

### Street Light Production Line



2000T,1000T,630T,250T Die-casting Machines



Electrostatic Powder Coating Line



Assembly Line

### LED Production Line



LED Solder Paste



LED Welding Machine



LED Chips Router



LED Assembly Line



LED Light Aging Test Shelf



LED Light Aging Test Line





# Light Poles Manufacture

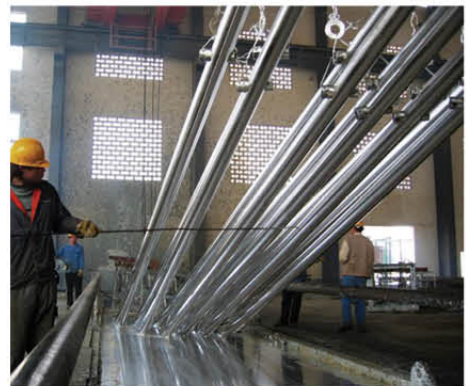
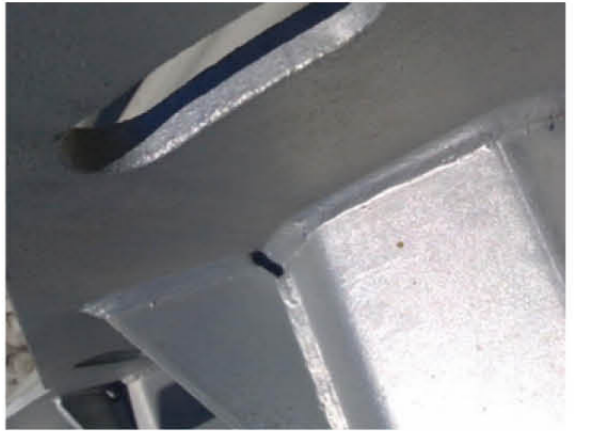
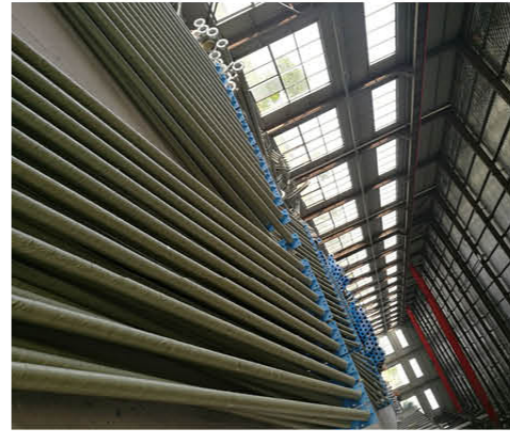

Every month, **30** Containers  
Every year, **100000** poles  
Every year, **250000** lamps  
Export over **40** countries



# Solution & Case



Mojo Dry Port, Ethiopia



Jordan



Saudi Arabia



Tunisie

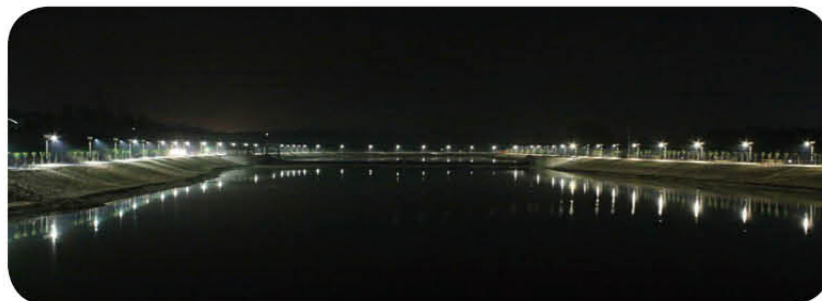

Weifang, China



Vietnam



Shandong, China



Iran

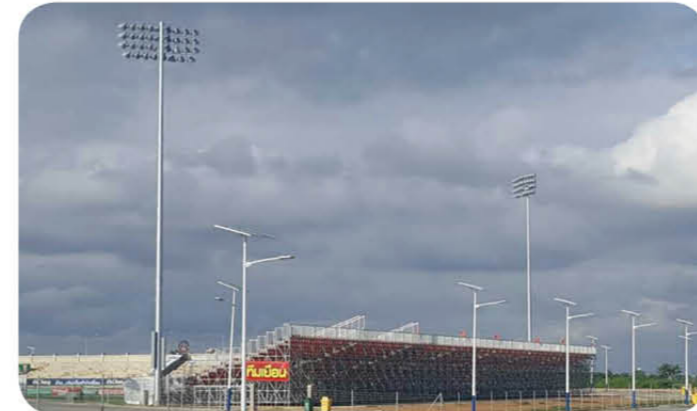

Thailand



Malaysia



Changchun, china



















Mexico









Jiangsu, China

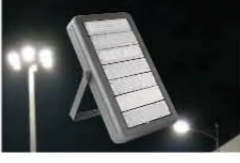

# CERTIFICATION

<p><b>ISO9001 2008</b></p> 	<p><b>ISO14001</b></p> 	<p><b>OHSAS18001</b></p> 	<p><b>CCC</b></p> 	<p><b>CQC</b></p> 
<p><b>ROHS-LED</b></p> 	<p><b>ROHS-HID</b></p> 	<p><b>CE-LIGHT POLE</b></p> 	<p><b>CE-LVD</b></p> 	<p><b>CE-EMC</b></p> 
		<p><b>SAA</b></p> 	<p><b>IP68</b></p> 	<p><b>IK08</b></p> 
<p><b>CHINA CERTIFICATE FOR ENERGY CONSERVATION PRODUCT</b></p>   				

# CONTENTS

	<p><b>01</b></p> <p>LED Module LED 模组</p>
	<p><b>03</b></p> <p>LED Street Light LED 路灯</p>
	<p><b>37</b></p> <p>LED Garden Light LED 庭院灯</p>
	<p><b>49</b></p> <p>LED Flood Light LED 投光灯</p>
	<p><b>55</b></p> <p>LED High Bay Light LED 工矿灯</p>
	<p><b>57</b></p> <p>Integrated Solar Street Light 一体化太阳能路灯</p>
	<p><b>63</b></p> <p>Integrated Solar Garden Light 一体化太阳能庭院灯</p>
	<p><b>65</b></p> <p>Integrated Solar Lawn Light 一体化太阳能草坪灯</p>

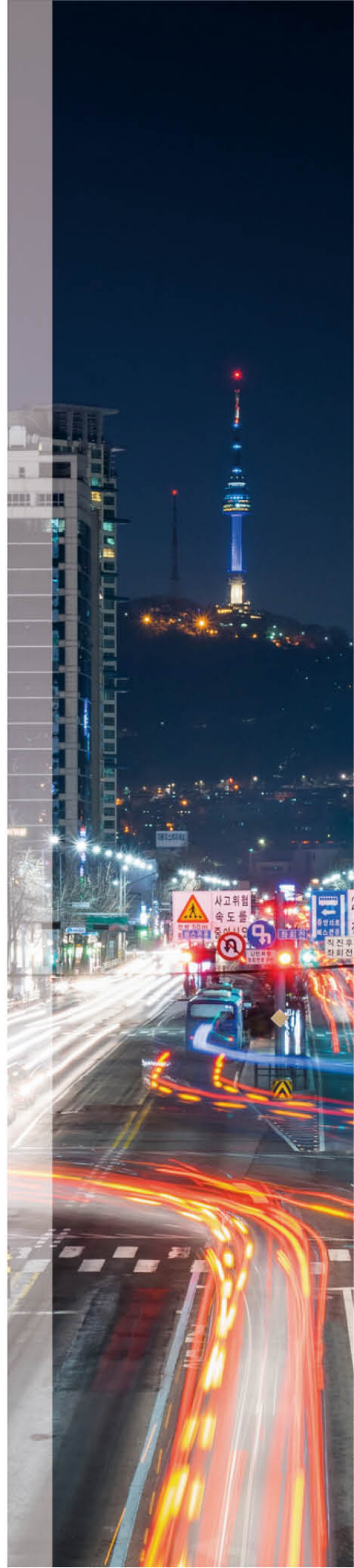



# LED Module



- 3 & 5-step MacAdam ellipse: Freedom from Binning for superior Quality of Light
- No gold eutectic solder the LED, avoid break dead lamp risk
- Superior efficacy and light output from a compact source

# LIGHTING HMOSTAR

LED 模组 LED Module

## TESTED IN THE WATER

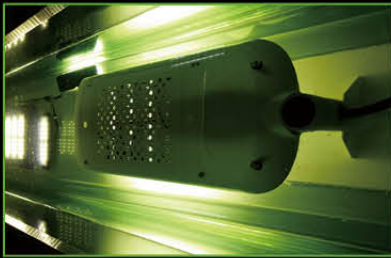

## IP68

## Light Distribution

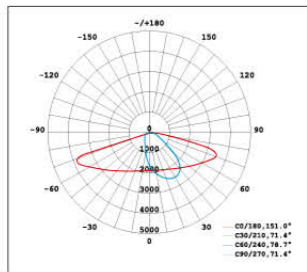

Batwing lighting distribution

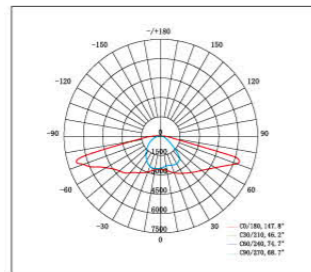

Batwing lighting distribution

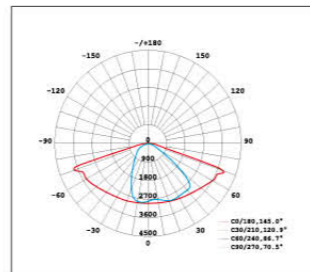

Batwing lighting distribution

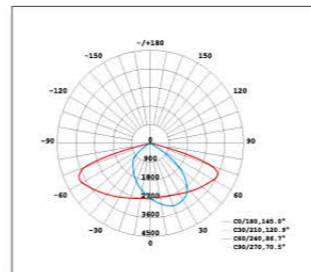

Batwing lighting distribution

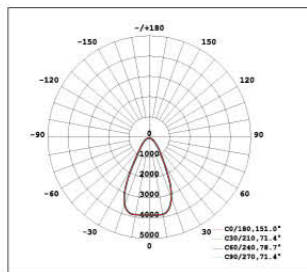

60° lighting distribution

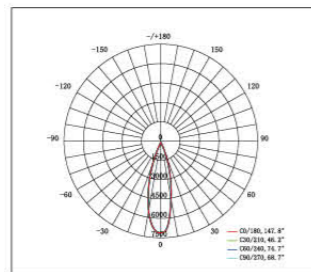

30° lighting distribution

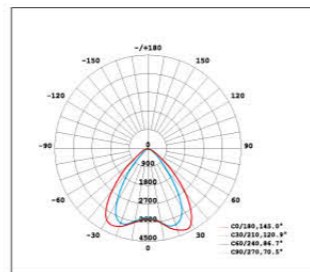

80° lighting distribution

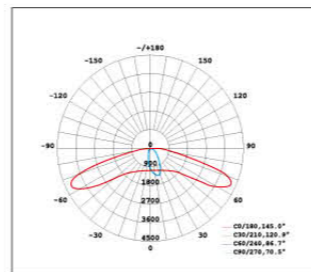

Batwing lighting distribution

Multiple colors are available on option

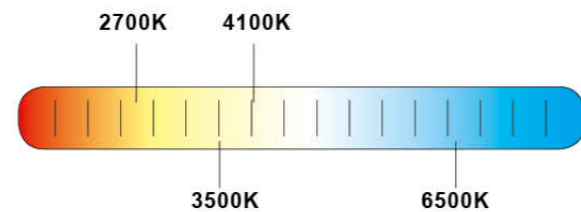

Model	HD-M18
Power	30W-40W
Light Efficacy	100lm-150lm/w
Input Voltage	48V
Color Rendering	RA70, RA80
LED Chips	EMC3535-18C
Module Size	298*70*47mm
Beam Angle	70°/150°



Model	HD-M30
Power	30W-70W
Light Efficacy	100lm-150lm/w
Input Voltage	42V~45V
Color Rendering	RA70, RA80
LED Chips	EMC5050-15C2B
Module Size	298*70*47mm/ 298*70*33mm
Beam Angle	80°/150°/60°/90°



Model	HD-M48
Power	30W-40W
Light Efficacy	100lm-150lm/w
Input Voltage	48V
Color Rendering	RA70, RA80
LED Chips	EMC3030-8C6B /16C3B
Module Size	298*70*47mm
Beam Angle	70°/150°



Model	HD-M64
Power	30W-70W
Light Efficacy	100lm-150lm/w
Input Voltage	48V~50V
Color Rendering	RA70, RA80
LED Chips	EMC3030-8C8B
Module Size	298*70*47mm/ 298*70*33mm
Beam Angle	80°/150°/45°/135°/30°/60°/90°



Model	HD-PLM
Power	30W-40W
Light Efficacy	100lm-150lm/w
Input Voltage	36V
Color Rendering	RA70, RA80
LED Chips	EMC3030-6C8B /6C7B
Module Size	298*70*47mm
Beam Angle	85°/135°



Model	HD-RM10	HD-RM20
Power	10W	20W
Light Efficacy	100lm-150lm/w	100lm-150lm/w
Input Voltage	36V	36V
Color Rendering	RA70, RA80	RA70, RA80
LED Chips	EMC3030-5C2B	EMC3030-5C4B
Module Size	Φ 60mm	Φ 90mm
Beam Angle	Type III V	Type III V



Model	HD-YM30
Power	60W
Light Efficacy	140lm-170lm/w
Maximum Current	1200mA
Color Rendering	RA70, RA80
LED Chips	EMC5050-2C15B
Module Size	299*70*51mm
Beam Angle	80°/150°/60°/90°



Model	HD-YM66
Power	60W
Light Efficacy	100lm-130lm/w
Maximum Current	1050mA
Color Rendering	RA70, RA80
LED Chips	EMC3030-9C7B
Module Size	299*70*53mm
Beam Angle	80°/150°/60°/90°



Model	HD-YM20
Power	50W
Light Efficacy	110lm-150lm/w
Maximum Current	1050mA
Color Rendering	RA70, RA80
LED Chips	EMC5050-2C9B
Module Size	175*100*51mm
Beam Angle	80°/150°/60°/90°



Model	HD-SM40
Power	30W-40W
Light Efficacy	100lm-150lm/w
Input Voltage	42V~45V
Color Rendering	RA70, RA80
LED Chips	EMC3030-5C8B
Module Size	168*100*33mm
Beam Angle	70°/145°/80°/150°



Model	HD-SM64
Power	60W
Light Efficacy	100lm-150lm/w
Input Voltage	42V~45V
Color Rendering	RA70, RA80
LED Chips	EMC3030-8C8B
Module Size	168*130*33mm
Beam Angle	80°/150°/90°



### HD002(ZDL1813) Series

- 高强度压铸铝材料，表面抗老化，静电喷涂处理；
- 耐腐蚀性强，钢化玻璃；
- 光学透镜多样设计，适应不同道路需求，IP66；



#### Features

- Smooth lamp shell design to ensure rainwater scouring, prevents dust accumulation and effective snow drainage.
- Stronger body with high pressure die-cast aluminium alloy housing and less weight ensures Impact grade reaches >IK08
- High efficiency coatings, paint and metal parts successfully pass 600 hours salt spray test.
- High transparent optical lens Tempered glass and different types lens for choice.
- Enough space for installing more devices like Zigbee controller / wireless control system to establish smart city operation for energy conservation and environmental protection.

#### Specification

产品型号	Product Code	HD002(ZDL1813)	HD002(ZDL1813)	HD002(ZDL1813)	HD002(ZDL1813)
额定功率	Rated Power	40W	60W	80W	100W
色温	CCT	3000K-6500K	3000K-6500K	3000K-6500K	3000K-6500K
初始光通量	Luminous Flux	120LM/W	120LM/W	120LM/W	120LM/W
安装孔径	Installation Diameter	Φ60mm	Φ60mm	Φ60mm	Φ60mm
净重 / 毛重	N.W./G.W.	4.5KGS/5.5KGS	4.9KGS/5.9KGS	5.2KGS/6.2KGS	5.4KGS/6.4KGS
产品尺寸 (mm)	Product Size	644*270*133	644*270*133	644*270*133	644*270*133
包装尺寸 (mm)	Packing Size	700*330*200	700*330*200	700*330*200	700*330*200

#### Size(mm)

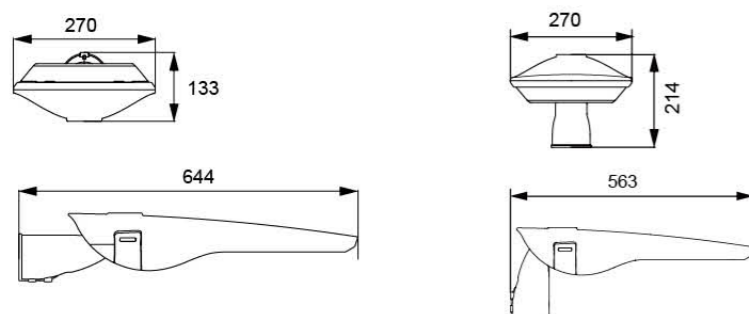

Daylight Sensor  
Timing Control  
光控器 / 智能分段控制器



Various Optical Lens for 3030 or 5050  
可配 3030 或 5050 透镜



Driver  
IP67 品牌电源

SPD  
防浪涌

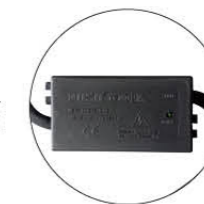

Power-off Protector  
断电保护开关



Breather  
呼吸器



Good Transparency 92%  
Tempered Glass  
超白玻璃

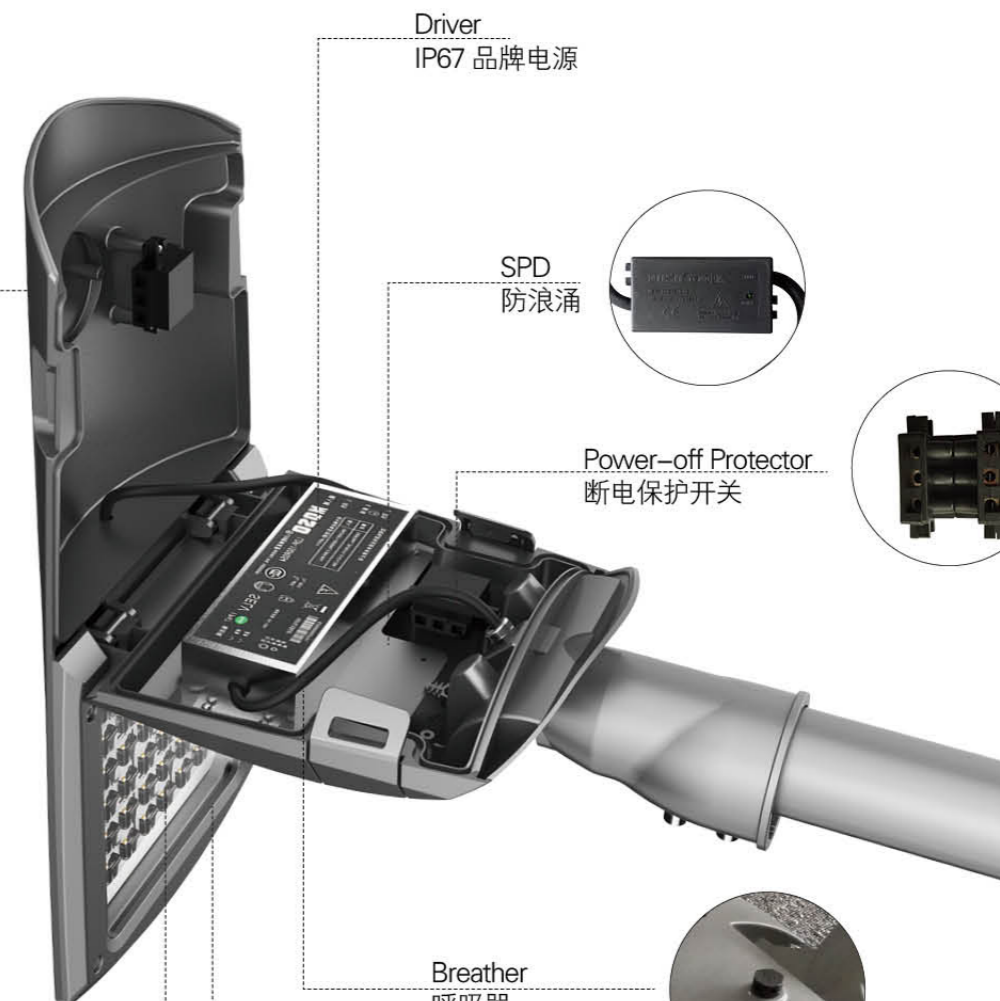

#### Light Distribution Curve

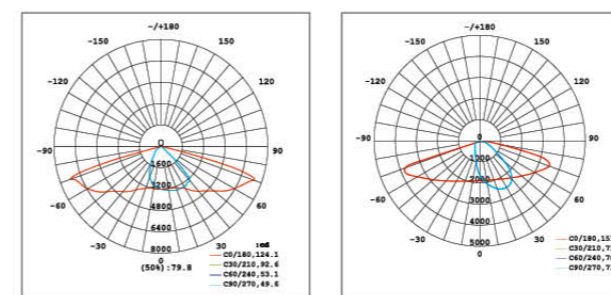



### HD001(ZDL1812) Series

- 高强度压铸铝材料，表面抗老化，静电喷涂处理；
- 耐腐蚀性强，钢化玻璃；
- 光学透镜多样设计，适应不同道路需求，IP66；



#### Features

- Module optical lens design that enhance the heat pin performance of the fixture.
- Stronger body with high pressure die-cast aluminium alloy housing with less weight ensures Impact grade reaches >IK08
- High efficiency coatings, paint and metal parts successfully pass 600 hours salt spray test.
- High transparent optical lens and Tempered glass, different types lens for choice.
- With surge protector lamp can reach Class II (10KV) or Class II.
- Enough space for installing more devices like Zigbee controller / wireless control system to establish smart city operation for energy conservation and environmental protection.

#### Specification

产品型号	Product Code	HD001C(ZDL1812)	HD001C(ZDL1812)	HD001C(ZDL1812)
额定功率	Rated Power	120W	150W	180W
色温	CCT	3000K-6500K	3000K-6500K	3000K-6500K
初始光通量	Luminous Flux	120LM/W	120LM/W	120LM/W
安装孔径	Installation Diameter	Φ60mm	Φ60mm	Φ60mm
净重 / 毛重	N.W./G.W.	7.0KGS/8.0KGS	7.4KGS/8.4KGS	7.8KGS/8.8KGS
产品尺寸 (mm)	Product Size	810*360*155	810*360*155	810*360*155
包装尺寸 (mm)	Packing Size	770*370*220	770*370*220	770*370*220

#### Size(mm)

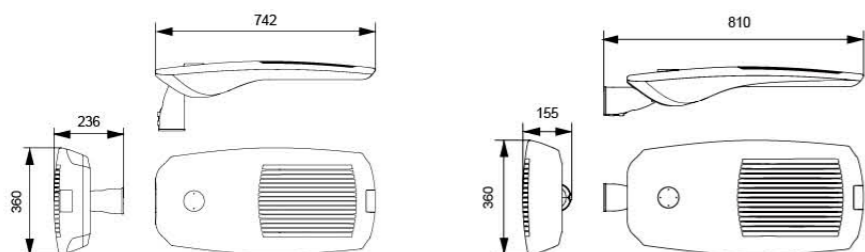

Daylight Sensor  
Timing Control  
光控器 / 智能分段控制器



Various Optical Lens for 3030 or 5050  
可配 3030 或 5050 透镜



Driver  
IP67 品牌电源



SPD  
防浪涌



Breather  
呼吸器



Option: PC control gear  
plate tool free  
可选: 电器板免工具



#### Light Distribution Curve

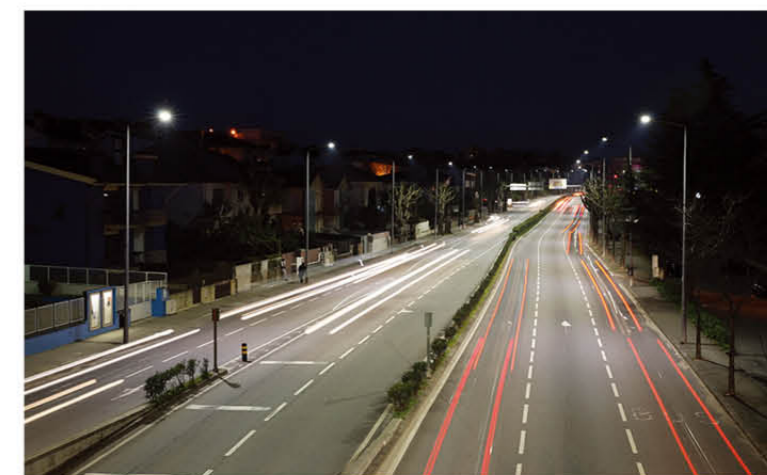
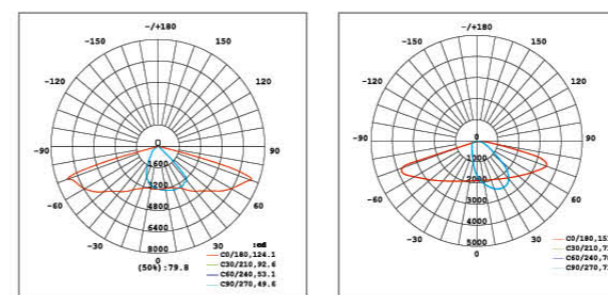



HD046 Series



**Applications**

High ways, primary streets, through ways, secondary streets, Driver ways, resident areas, parking lots, gardens and so on.

**Features**

- Modern fashion design of appearance, good heat sink proving long life of the LEDs.
- High strength aluminum die casting material, surface anti-ageing electrostatic spray process.
- High performance patent optical lens, different types lens for choice.
- Heatproof and shockproof tempered glass.
- High stress stainless fastening pieces.

**Advantages**



- Horizontal & vertical installation



- Smooth design, selfcleaning capability.



- High light transmittance optical lens.



- Reliable long life driver & 10KV SPD.

**Specification**

产品型号	Product Code	HD046A	HD046B	HD046C
额定功率	Rated Power	60W-150W	150W-200W	200W-300W
色温	CCT	3000K-6500K	3000K-6500K	3000K-6500K
初始光通量	Luminous Flux	130LM/W	130LM/W	130LM/W
安装孔径	Installation Diameter	Φ60mm	Φ60mm	Φ60mm
产品尺寸 (mm)	Product Size	661*321*172	762*321*172	863*321*172

**Light Distribution Curve**

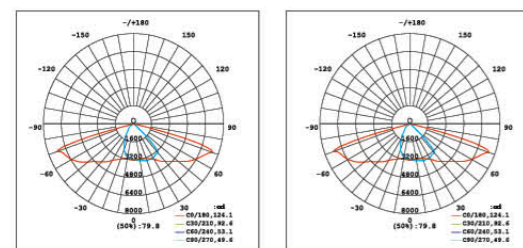

**Size(mm)**

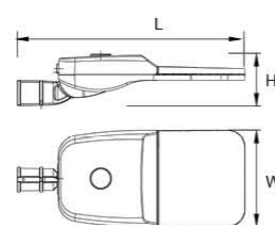

HD047 Series



**Applications**

High ways, primary streets, through ways, secondary streets, Driver ways, resident areas, parking lots, gardens and so on.

**Features**

- Modern fashion design of appearance, good heat sink proving long life of the LEDs.
- High strength aluminum die casting material, surface anti-ageing electrostatic spray process.
- High performance patent optical lens, different types lens for choice.
- Heatproof and shockproof tempered glass.
- High stress stainless fastening pieces.

**Advantages**



- Horizontal & vertical installation



- Heat sink design, selfcleaning capability.



- High light transmittance optical lens.



- Reliable long life driver & 10KV SPD.

**Specification**

产品型号	Product Code	HD047A	HD047B	HD047C
额定功率	Rated Power	60W-150W	150W-200W	200W-300W
色温	CCT	3000K-6500K	3000K-6500K	3000K-6500K
初始光通量	Luminous Flux	130LM/W	130LM/W	130LM/W
安装孔径	Installation Diameter	Φ60mm	Φ60mm	Φ60mm
产品尺寸 (mm)	Product Size	661*321*172	762*321*172	863*321*172

**Light Distribution Curve**

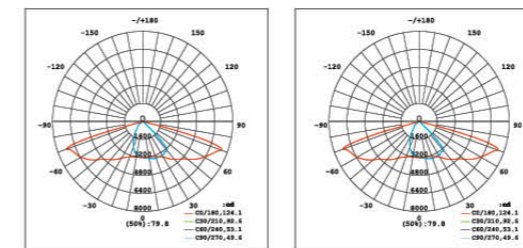

**Size(mm)**

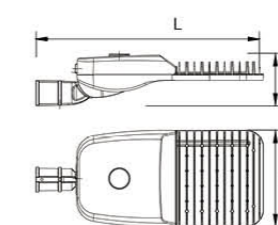



HD048 Series



**Applications**

High ways, primary streets, through ways, secondary streets, Driver ways, resident areas, parking lots, gardens and so on.

**Features**

- Modern fashion design of appearance, excellent self-cleaning capability.
- Used in high strength aluminum die casting material, surface anti-ageing electrostatic spray process, super resistance to corrosion.
- High transparent optical lens and Tempered glass.
- Horizontal installation: +10°~ -10°adjustable;
- Vertical installation: +10°~ -10°adjustable.
- Different types lens for choice.
- IK08

**Advantages**



- Horizontal & vertical installation



- Smooth design, selfcleaning capability.



- High light transmittance optical lens.

**Specification**

产品型号	Product Code	HD048A	HD048B	HD048C	HD048D	HD048E
额定功率	Rated Power	60W	80W	120W	150W	200W
色温	CCT	3000K-6500K	3000K-6500K	3000K-6500K	3000K-6500K	3000K-6500K
初始光通量	Luminous Flux	130LM/W	130LM/W	130LM/W	130LM/W	130LM/W
安装孔径	Installation Diameter	Φ48mm	Φ60mm	Φ60mm	Φ60mm	Φ60mm
净重 / 毛重	N.W./G.W.	3.3KGS/3.8KGS	3.5KGS/4KGS	5.2KGS/6KGS	5.5KGS/6.2KGS	5.5KGS/6.2KGS
产品尺寸( mm )	Product Size	523*199*135	600*245*155	636*290*155	686*290*155	755*310*155
包装尺寸( mm )	Packing Size	575*225*125	660*270*135	685*310*140	735*310*140	815*330*150

**Light Distribution Curve**

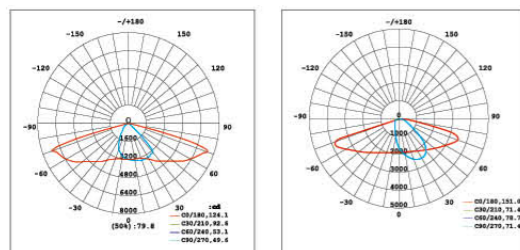

**Size(mm)**

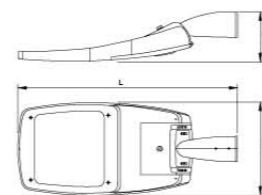

HD049 Series



**Applications**

High ways, primary streets, through ways, secondary streets, Driver ways, resident areas, parking lots, gardens and so on.

**Features**

- Modern fashion design of appearance, good heat sink proving long life of the LEDs.
- High strength aluminum die casting material, surface anti-ageing electrostatic spray process.
- High performance patent optical lens, different types lens for choice.
- Heatproof and shockproof tempered glass.
- High stress stainless fastening pieces.

**Advantages**



- Adjustable spigot 0°



- Adjustable spigot 0° /90°



- Auto-cleaning



- Photocell and controller

**Specification**

产品型号	Product Code	HD049A	HD049B	HD049C	HD049D
额定功率	Rated Power	100W	150W/200W	100W	200W
色温	CCT	3000K-6500K	3000K-6500K	3000K-6500K	3000K-6500K
初始光通量	Luminous Flux	130LM/W	130LM/W	130LM/W	130LM/W
安装孔径	Installation Diameter	Φ60mm	Φ60mm	Φ60mm	Φ60mm
产品尺寸( mm )	Product Size	500*245*75	600*295*90	660*245*75	750*295*90
包装尺寸( mm )	Packing Size	520*265*95	620*315*110	685*310*140	770*315*110

**Light Distribution Curve**

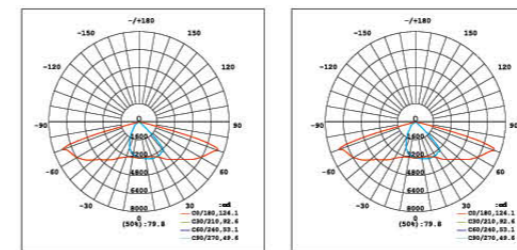

**Size(mm)**

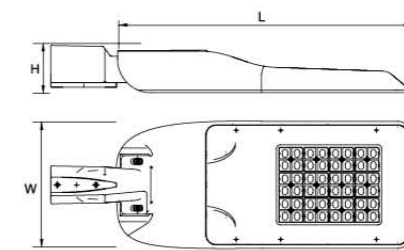



HD508 Series

- 高强度压铸铝材料，表面抗老化，静电喷涂处理，耐腐蚀性强；
- 双液压支撑，方便开启维护；
- 密封电源腔体，IP68；
- 光学透镜多样设计，适应不同道路需求；

10%~90%  
 +50°C / -35°C  
 50,000h  
 CRI >75  
 PF >0.95  
 AC85~265V



Features

- High strength aluminum die casting material, surface anti-ageing electrostatic spraying processing, super resistance to corrosion.
- Modular design: 1-6 pcs modules for choice.
- High light transmittance optical lens.
- Modules and back board made with air flow design, reduce the lamps working temperature.

Specification

产品型号	Product Code	HD508-2	HD508-3	HD508-4	HD508-5
额定功率	Rated Power	120W	180W	240W	300W
色温	CCT	3000K-6500K	3000K-6500K	3000K-6500K	3000K-6500K
初始光通量	Luminous Flux	120-160LM/W	120-160LM/W	120-160LM/W	120-160LM/W
安装孔径	Installation Diameter	Φ60mm	Φ60mm	Φ60mm	Φ60mm
净重 / 毛重	N.W./G.W.	7.8KGS/8.8KGS	9.2KGS/10.4KGS	10.2KGS/11.6KGS	11.7KGS/13.5KGS
产品尺寸 (mm)	Product Size	638*355*132	722*355*132	806*355*132	890*355*132
包装尺寸 (mm)	Packing Size	690*380*155	780*380*155	865*380*155	945*380*155

Size(mm)

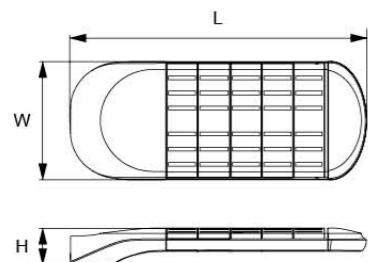

Easy Mintenance  
扣攀设计让安装维修

Air flow design  
后盖开孔散热

Driver  
IP67 品牌电源

LED Module IP68  
LED 模组 IP68

Waterproof Conector  
防水接头

Light Distribution Curve

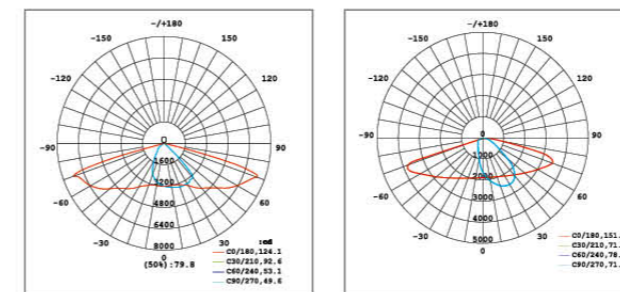



HD030 Series



**Applications**

High ways, primary streets, through ways, secondary streets, Driver ways, resident areas, parking lots, gardens and so on.

**Features**

- Modern fashion design of appearance, good heat sink proving long life of the LEDs.
- High strength aluminum die casting material, surface anti-ageing electrostatic spray process.
- High performance patent optical lens, different types lens for choice.
- Heatproof and shockproof tempered glass.
- High stress stainless fastening pieces.

**Advantages**



• 16 in 1 Optical Lens



• Photocell and controller

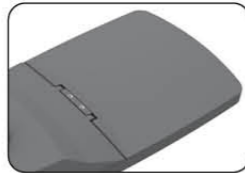

• Auto-cleaning

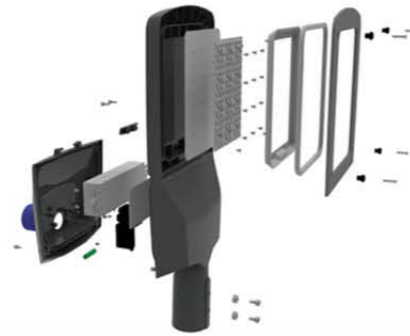

**Specification**

产品型号	Product Code	HD030A	HD030B	HD030C
额定功率	Rated Power	60W	150W	200W
色温	CCT	3000K-6500K	3000K-6500K	3000K-6500K
初始光通量	Luminous Flux	120LM/W	120LM/W	120LM/W
安装孔径	Installation Diameter	Φ60mm	Φ60mm	Φ60mm
净重 / 毛重	N.W./G.W.	3.5KGS/4KGS	5.5KGS/6.5KGS	8KGS/9.5KGS
产品尺寸 ( mm )	Product Size	508*203*110	655*275*110	760*328*130

**Light Distribution Curve**

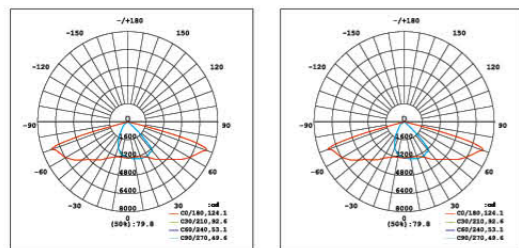

**Size(mm)**

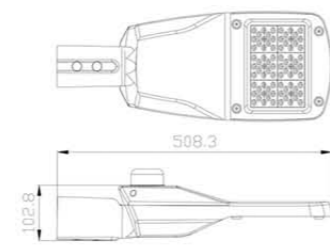

HD006 Series



**Applications**

High ways, primary streets, through ways, secondary streets, Driver ways, resident areas, parking lots, gardens and so on.

**Features**

- Module optical lens design that enhance the heat pin performance of the fixture.
- Stronger body with high pressure die-cast aluminium alloy housing with less weight ensures Impact grade reaches >IK08
- High efficiency coatings, paint and metal parts successfully pass 600 hours salt spray test.
- High transparent optical lens and Tempered glass, different types lens for choice.
- With surge protector lamp can reach Class II (10KV) or Class II.
- Enough space for installing more devices like Zigbee controller / wireless control system to establish smart city operation for energy conservation and environmental protection.

**Advantages**



• Various Optical Lens for 3030 or 5050



• Adjustable spigot 0° /90°



• Easy open



• Photocell and controller



• Auto-cleaning

**Specification**

产品型号	Product Code	HD006A	HD006A	HD006B	HD006B
额定功率	Rated Power	60W	80W	100W	120W
色温	CCT	3000K-6500K	3000K-6500K	3000K-6500K	3000K-6500K
初始光通量	Luminous Flux	120LM/W	120LM/W	120LM/W	120LM/W
安装孔径	Installation Diameter	Φ50mm Φ60mm	Φ50mm Φ60mm	Φ60mm	Φ60mm
净重 / 毛重	N.W./G.W.	4.2KGS/5KGS	4.3KGS/5.1KGS	5.4KGS/6.4KGS	5.5KGS/6.5KGS
产品尺寸 ( mm )	Product Size	555*250*110	555*250*110	670*275*110	670*275*110
包装尺寸 ( mm )	Packing Size	630*300*150	630*300*150	725*300*150	725*300*150

**Light Distribution Curve**

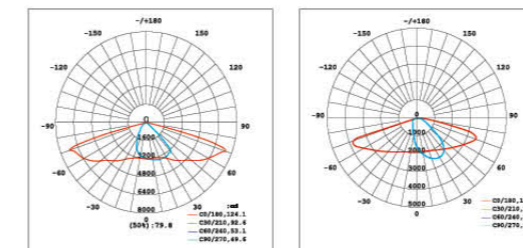

**Size(mm)**

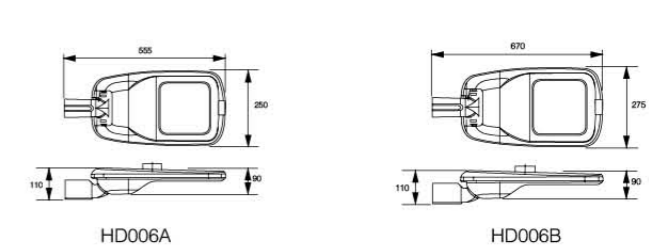



HD011 Series



Applications

High ways, primary streets, through ways, secondary streets, Driver ways, resident areas, parking lots, gardens and so on.

Features

- Modern fashion design of appearance, good heat sink proving long life of the LEDs.
- High strength aluminum die casting material, surface anti-ageing electrostatic spray process.
- High performance patent optical lens, different types lens for choice.
- Standard mast-arm mounting: 60mm with inclination form -15° to +15° in steps of 5°



Advantages

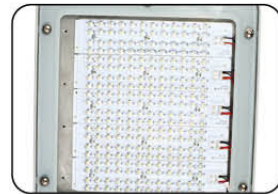

• Various Optical Lens for 3030 or 5050



• Adjustable spigot 0°/90°



• Photocell and controller



• Reliable long life driver & 10KV SPD.

Specification

产品型号	Product Code	HD011A	HD011B	HD011C	HD011D
额定功率	Rated Power	60W-120W	150W-200W	240W-300W	300W-400W
色温	CCT	3000K-6500K	3000K-6500K	3000K-6500K	3000K-6500K
初始光通量	Luminous Flux	130LM/W	130LM/W	130LM/W	130LM/W
安装孔径	Installation Diameter	Φ60mm	Φ60mm	Φ60mm	Φ60mm
产品尺寸 (mm)	Product Size	622*320*119	720*320*119	902*320*119	1090*350*119

Size(mm)

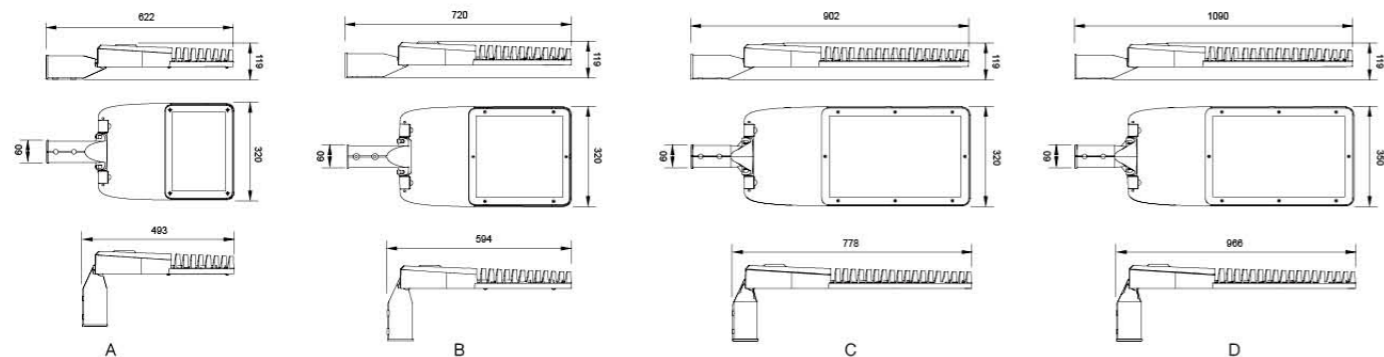

HD025 Series



Applications

High ways, primary streets, through ways, secondary streets, Driver ways, resident areas, parking lots, gardens and so on.

Features

- Modern fashion design of appearance, good heat sink proving long life of the LEDs.
- High strength aluminum die casting material, surface anti-ageing electrostatic spray process.
- High performance patent optical lens, different types lens for choice.
- Heatproof and shockproof tempered glass.
- High stress stainless fastening pieces.



Advantages



• 16 in 1 Optical Lens



• Adjustable spigot 0° /90°



• Photocell and controller

Specification

产品型号	Product Code	HD025A	HD025B
额定功率	Rated Power	20W-60W	60W-120W
色温	CCT	3000K-6500K	3000K-6500K
初始光通量	Luminous Flux	130LM/W	130LM/W
安装孔径	Installation Diameter	Φ60mm	Φ60mm
净重 / 毛重	N.W./G.W.	3.3KGS/3.8KGS	3.5KGS/4KGS
产品尺寸 (mm)	Product Size	480*220*85	580*250*85

Light Distribution Curve

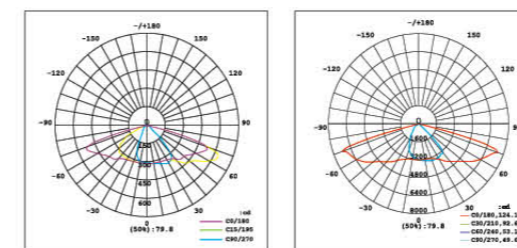

Size(mm)

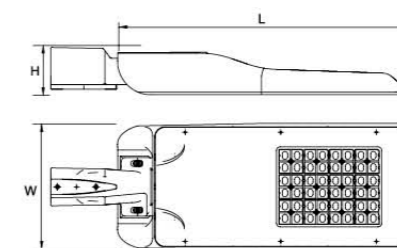



HD013 Series



**Applications**

High ways, primary streets, through ways, secondary streets, Driver ways, resident areas, parking lots, gardens and so on.

**Features**

- Modern fashion design of appearance, good heat sink proving long life of the LEDs.
- High strength aluminum die casting material, surface anti-ageing electrostatic spray process.
- High performance patent optical lens, different types lens for choice.
- Heatproof and shockproof tempered glass.
- High stress stainless fastening pieces.

**Advantages**

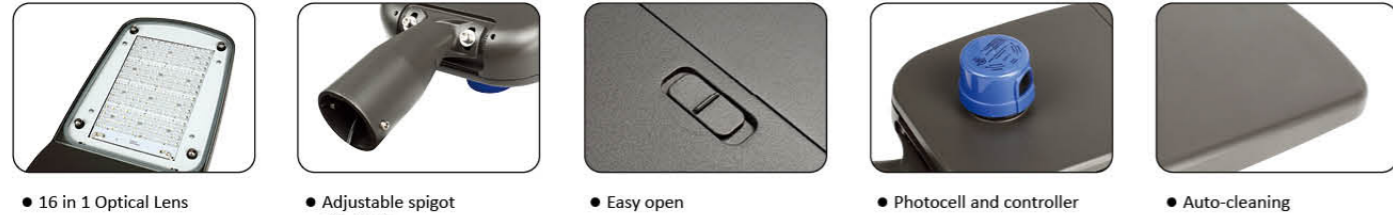

- 16 in 1 Optical Lens
- Adjustable spigot 0° /90°
- Easy open
- Photocell and controller
- Auto-cleaning

**Specification**

产品型号	Product Code	HD013A	HD013A	HD013B	HD013B	HD013C	HD013C
额定功率	Rated Power	30W	60W	80W	120W	150W	200W
色温	CCT	3000K-6500K	3000K-6500K	3000K-6500K	3000K-6500K	3000K-6500K	3000K-6500K
初始光通量	Luminous Flux	130LM/W	130LM/W	130LM/W	130LM/W	130LM/W	130LM/W
安装孔径	Installation Diameter	Φ60mm	Φ60mm	Φ60mm	Φ60mm	Φ60mm	Φ60mm
净重 / 毛重	N.W./G.W.	3.3KGS/3.8KGS	3.5KGS/4KGS	5.2KGS/6KGS	5.5KGS/6.2KGS	6.7KGS/7.8KGS	9KGS/11.2KGS
产品尺寸 (mm)	Product Size	600*210*109	600*210*109	706*265*119	706*265*119	880*352*140	880*352*140

**Light Distribution Curve**

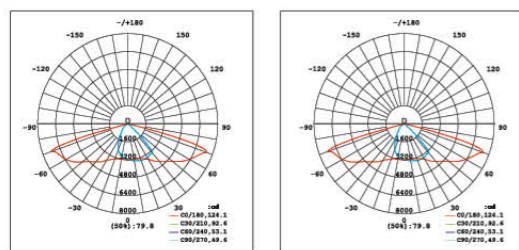

**Size(mm)**

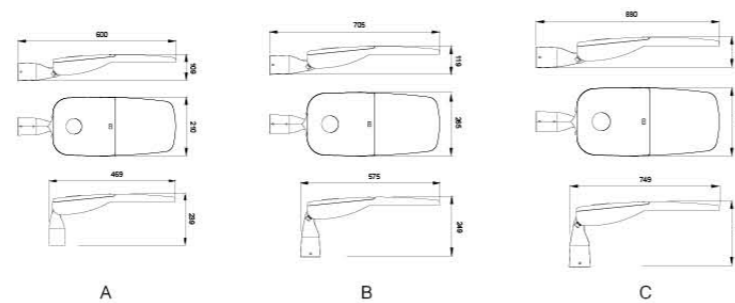

HD003 Series



**Applications**

High ways, primary streets, through ways, secondary streets, Driver ways, resident areas, parking lots, gardens and so on.

**Features**

- Modern fashion design of appearance, excellent self-cleaning capability.
- Used in high strength aluminum die casting material, surface anti-ageing electrostatic spray process, super resistance to corrosion.
- High transparent optical lens and Tempered glass.
- Horizontal installation: +10°~ -10°adjustable;
- Vertical installation: +10°~ -10°adjustable.
- Different types lens for choice.
- IK08

**Advantages**



- Horizontal & vertical installation
- Smooth design, selfcleaning capability.
- High light transmittance optical lens.
- Reliable long life driver.

**Specification**

产品型号	Product Code	HD003A	HD003B	HD003B	HD003C	HD003C	HD003D	HD003D
额定功率	Rated Power	30W	40W	80W	100W	150W	180W	200W
色温	CCT	3000K-6500K	3000K-6500K	3000K-6500K	3000K-6500K	3000K-6500K	3000K-6500K	3000K-6500K
初始光通量	Luminous Flux	110LM/W	110LM/W	110LM/W	110LM/W	110LM/W	110LM/W	110LM/W
安装孔径	Installation Diameter	Φ60mm	Φ60mm	Φ60mm	Φ60mm	Φ60mm	Φ60mm	Φ60mm
净重 / 毛重	N.W./G.W.	3.5KGS/4.3KGS	4.7KGS/5.6KGS	4.7KGS/5.6KGS	6.4KGS/7.8KGS	6.4KGS/7.8KGS	10.4KGS/11.5KGS	10.4KGS/11.5KGS
产品尺寸( mm )	Product Size	507*210*130	616*259*186	616*259*186	677*305*187	677*305*187	850*366*198	850*366*198
包装尺寸( mm )	Packing Size	570*246*140	680*295*150	680*295*150	750*355*165	750*355*165	910*425*195	910*425*195

**Light Distribution Curve**

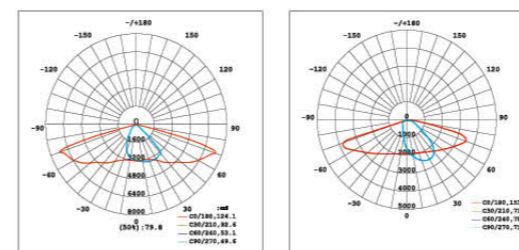

**Size(mm)**

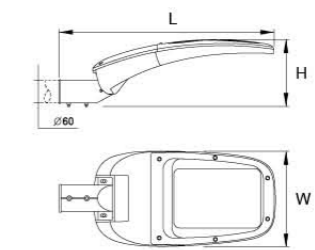



HD026 Series



**Applications**

High ways, primary streets, through ways, secondary streets, Driver ways, resident areas, parking lots, gardens and so on.

**Features**

- Modern fashion design of appearance, good heat sink proving long life of the LEDs.
- High strength aluminum die casting material, surface anti-ageing electrostatic spray process.
- High performance patent optical lens, different types lens for choice.
- Heatproof and shockproof tempered glass.
- High stress stainless fastening pieces.

**Advantages**



• Various Optical Lens



• Adjustable spigot 0° /90°

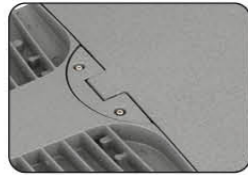

• Easy open



• Photocell and controller

**Specification**

产品型号	Product Code	HD026A	HD026A	HD026B	HD026B	HD026C	HD026C
额定功率	Rated Power	30W	80W	150W	200W	250W	300W
色温	CCT	3000K-6500K	3000K-6500K	3000K-6500K	3000K-6500K	3000K-6500K	3000K-6500K
初始光通量	Luminous Flux	120LM/W	120LM/W	120LM/W	120LM/W	120LM/W	120LM/W
安装孔径	Installation Diameter	Φ60mm	Φ60mm	Φ60mm	Φ60mm	Φ60mm	Φ60mm
净重 / 毛重	N.W./G.W.	3.3KGS/3.8KGS	3.5KGS/4KGS	5.2KGS/6KGS	5.5KGS/6.2KGS	8.7KGS/9.8KGS	9KGS/11.2KGS
产品尺寸 (mm)	Product Size	588*350*118	588*350*118	688*350*118	688*350*118	788*350*118	788*350*118

**Light Distribution Curve**

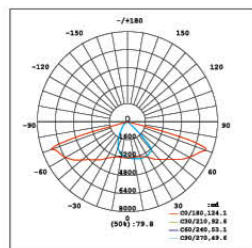

**Size(mm)**

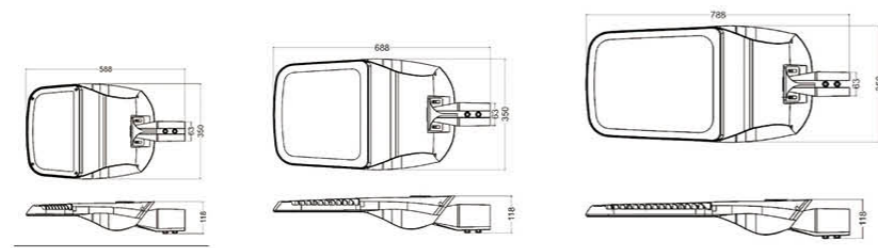

HD031 Series



**Applications**

High ways, primary streets, through ways, secondary streets, Driver ways, resident areas, parking lots, gardens and so on.

**Features**

- Modern fashion design of appearance, good heat sink proving long life of the LEDs.
- High strength aluminum die casting material, surface anti-ageing electrostatic spray process.
- High performance patent optical lens, different types lens for choice.
- Heatproof and shockproof tempered glass.
- High stress stainless fastening pieces.

**Advantages**



• 16 in 1 Optical Lens



• Adjustable spigot 0° /90°



• Auto-cleaning



• Photocell and controller

**Specification**

产品型号	Product Code	HD031A	HD031A	HD031B	HD031B
额定功率	Rated Power	100W	150W	200W	250W
色温	CCT	3000K-6500K	3000K-6500K	3000K-6500K	3000K-6500K
初始光通量	Luminous Flux	130LM/W	130LM/W	130LM/W	130LM/W
安装孔径	Installation Diameter	Φ60mm	Φ60mm	Φ60mm	Φ60mm
产品尺寸 (mm)	Product Size	560*262*106	560*262*106	658*292*106	658*292*106

**Light Distribution Curve**

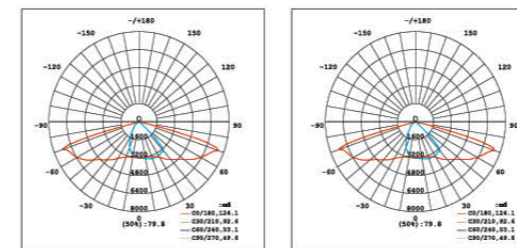

**Size(mm)**

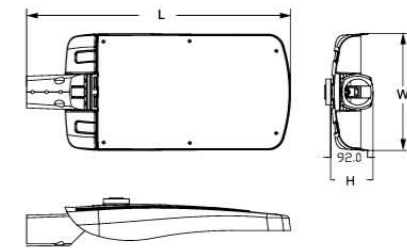



HD034 Series



**Applications**

High ways, primary streets, through ways, secondary streets, Driver ways, resident areas, parking lots, gardens and so on.

**Features**

- Modern fashion design of appearance, good heat sink proving long life of the LEDs.
- High strength aluminum die casting material, surface anti-ageing electrostatic spray process.
- High performance patent optical lens, different types lens for choice.
- Heatproof and shockproof tempered glass.
- High stress stainless fastening pieces.

**Advantages**



- 16 in 1 Optical Lens
- Adjustable spigot 0° /90°
- Easy open
- Photocell and controller

**Specification**

产品型号	Product Code	HD034A	HD034A	HD034B	HD034B
额定功率	Rated Power	60W	90W	120W	200W
色温	CCT	3000K-6500K	3000K-6500K	3000K-6500K	3000K-6500K
初始光通量	Luminous Flux	130LM/W	130LM/W	130LM/W	130LM/W
安装孔径	Installation Diameter	Φ60mm	Φ60mm	Φ60mm	Φ60mm
净重 / 毛重	N.W./G.W.	3.3KGS/3.8KGS	3.5KGS/4KGS	5.2KGS/6KGS	5.5KGS/6.2KGS
产品尺寸 (mm)	Product Size	757*225*131	757*225*131	857*225*119	857*225*119

**Light Distribution Curve**

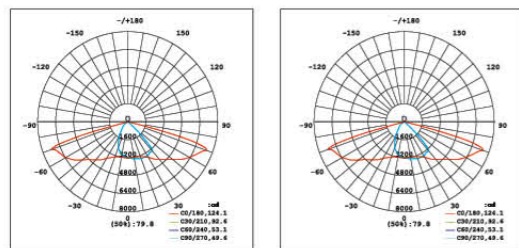

**Size(mm)**

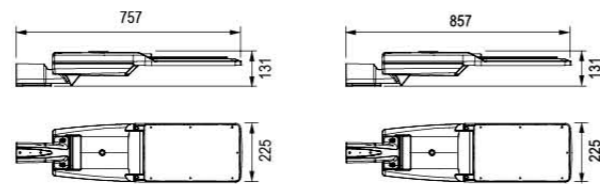

HD519 Series



**Applications**

High ways, primary streets, through ways, secondary streets, Driver ways, resident areas, parking lots, gardens and so on.

**Features**

- Modern fashion design of appearance, good heat sink proving long life of the LEDs.
- High strength aluminum die casting material, surface anti-ageing electrostatic spray process.
- High performance patent optical lens, different types lens for choice.
- Heatproof and shockproof tempered glass.
- High stress stainless fastening pieces.

**Advantages**



- Die-casting aluminum housing, IK08.
- High light transmittance optical lens.
- Switch fastener design for easily opening driver bay.
- Reliable long life driver & 10KV SPD.

**Specification**

产品型号	Product Code	HD519A	HD519A	HD519B	HD519B	HD519C	HD519D	HD519E
额定功率	Rated Power	60W	80W	120W	150W	200W	250W	300W
色温	CCT	3000K-6500K	3000K-6500K	3000K-6500K	3000K-6500K	3000K-6500K	3000K-6500K	3000K-6500K
初始光通量	Luminous Flux	120LM/W	120LM/W	120LM/W	120LM/W	120LM/W	120LM/W	120LM/W
安装孔径	Installation Diameter	Φ60mm	Φ60mm	Φ60mm	Φ60mm	Φ60mm	Φ60mm	Φ60mm
净重 / 毛重	N.W./G.W.	5.4KGS/6.3KGS	5.6KGS/6.5KGS	7KGS/8.7KGS	7.2KGS/8KGS	7.7KGS/9.5KGS	9KGS/11KGS	11.5KGS/14KGS
产品尺寸 (mm)	Product Size	422*320*140	422*320*140	522*320*140	522*320*140	600*320*140	700*320*140	853*320*140
包装尺寸 (mm)	Packing Size	430*340*165	430*340*165	532*340*165	532*340*165	610*340*165	710*340*165	863*340*165

**Light Distribution Curve**

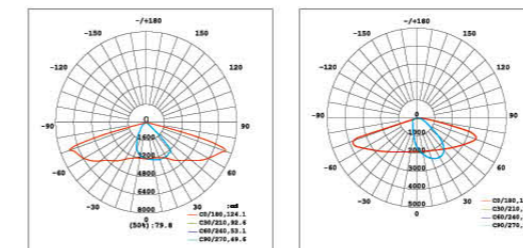

**Size(mm)**

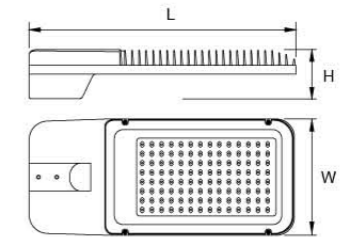



HD024 Series



**Applications**

High ways, primary streets, through ways, secondary streets, Driver ways, resident areas, parking lots, gardens and so on.

**Features**

- Modern fashion design of appearance , ultra thin fashion design.
- High strength aluminum die casting material, anti-ageing powder coat finish.
- Self-cleaning function to achieve best heat dissipation performance to ensure long life.
- Optical grade lens design, beam Angle type II lighting distributions meet area lighting requirement.
- Waterproof rating IP65 & IK08

**Advantages**



- High light transmittance optical lens.



- Tool free opening design, User friendly, easy maintenance.

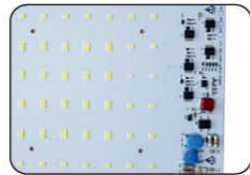

- Reliable long life LED .

**Specification**

产品型号	Product Code	HD024A	HD024B	HD024C	HD024D	HD024E
额定功率	Rated Power	20W	30W	50W	80W	100W
色温	CCT	3000K-6500K	3000K-6500K	3000K-6500K	3000K-6500K	3000K-6500K
初始光通量	Luminous Flux	110LM/W	110LM/W	110LM/W	110LM/W	110LM/W
安装孔径	Installation Diameter	Φ42mm	Φ42mm	Φ48mm	Φ60mm	Φ60mm
净重 / 毛重	N.W./G.W.	0.37KGS/0.6KGS	0.45KGS/0.7KGS	0.73KGS/1.2KGS	1.3KGS/1.8KGS	1.66KGS/2.3KGS
产品尺寸 ( mm )	Product Size	260*110*56	311*136*56	391*162*67	482*187*80	541*218*80
包装尺寸 ( mm )	Packing Size	270*120*76	321*146*76	401*172*87	490*197*100	550*228*100

**Light Distribution Curve**

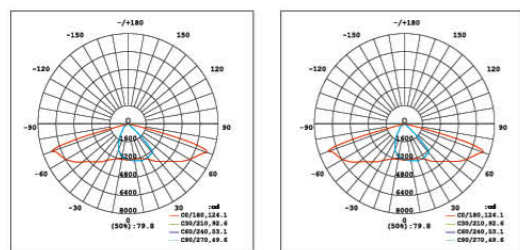

**Size(mm)**

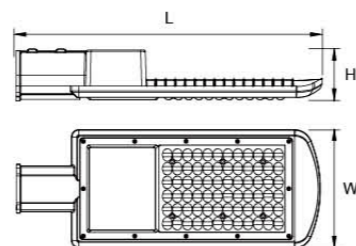

HD208 Series



**Applications**

High ways, primary streets, through ways, secondary streets, Driver ways, resident areas, parking lots, gardens and so on.

**Features**

- High lumen, high quality, High brightness, low consumption, green for environment.
- Easy to install and use, secure and reliable.
- Light body is made of good quality aluminum alloy with painting or anodic treatment on surface, exiguity and unique design, excellent heat dissipation.
- AC85-265V in different countries and regions. AC12/24V led driver is also available.
- Mesh shape heat sink, Good heat dissipation .

**Advantages**



- CREE/Bridgelux/Nichia/Epistar COB for choice



- Heat sink design



- High efficient optical lens



- IP68 brand driver

**Specification**

产品型号	Product Code	HD208A	HD208B	HD208C	HD208D	HD208E
额定功率	Rated Power	30W	50W	100W	150W	200W
色温	CCT	3000K-6500K	3000K-6500K	3000K-6500K	3000K-6500K	3000K-6500K
初始光通量	Luminous Flux	110LM/W	110LM/W	110LM/W	110LM/W	110LM/W
安装孔径	Installation Diameter	Φ48mm	Φ60mm	Φ60mm	Φ60mm	Φ60mm
净重 / 毛重	N.W./G.W.	2KGS/2.5KGS	3KGS/4KGS	4.1KGS/5.2KGS	7KGS/8.5KGS	11KGS/13KGS
产品尺寸 ( mm )	Product Size	500*220*90	620*270*95	720*280*95	880*335*110	1100*420*110
包装尺寸 ( mm )	Packing Size	510*230*110	630*280*110	730*300*110	890*350*130	1110*435*130

**Light Distribution Curve**

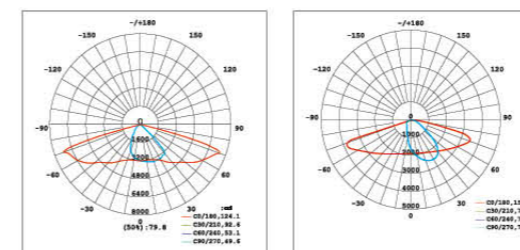

**Size(mm)**

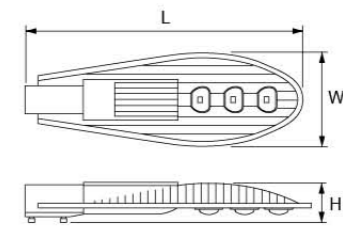



**HD2049**

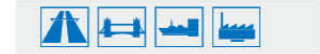

**Product Parameter:**

- Wattage Range: 80W-200W
- Efficiency: 120Lm/W~160Lm/W
- Power Efficiency: >90%
- Color Temperature: 3000~6500K
- Working Environment: -30°C~50°C
- IP Rating: IP68
- Installation Diameter: Φ60mm

**Eternal Dimension:**

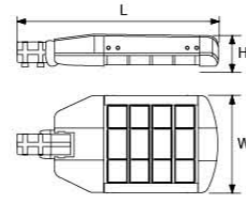

SIZE	L	W	H	Power
A	560	355	95	LED80W
B	640	355	95	LED120W
C	720	355	95	LED160W
D	800	355	95	LED200W

**HD520**



**Product Parameter:**

- Wattage Range: 60W-300W
- Efficiency: 120Lm/W~160Lm/W
- Power Efficiency: >90%
- Color Temperature: 3000~6500K
- Working Environment: -30°C~50°C
- IP Rating: IP68
- Installation Diameter: Φ60mm

**Eternal Dimension:**

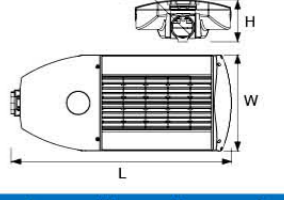

SIZE	L	W	H	Power
A	504	316	136	LED60W-100W
B	577	316	136	LED90W-150W
C	650	316	136	LED120W-200W
D	723	316	136	LED150W-250W
E	796	316	136	LED180W-300W

**HD2050**

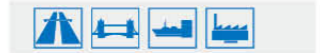

**Product Parameter:**

- Wattage Range: 80W-200W
- Efficiency: 100Lm/W~130Lm/W
- Power Efficiency: >90%
- Color Temperature: 3000~6500K
- Working Environment: -30°C~50°C
- IP Rating: IP68
- Installation Diameter: Φ60mm

**Eternal Dimension:**

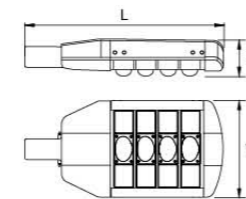

SIZE	L	W	H	Power
A	560	355	95	LED80W
B	640	355	95	LED120W
C	720	355	95	LED160W
D	800	355	95	LED200W

**HD028**



**Product Parameter:**

- Wattage Range: 100W-300W
- Efficiency: 100Lm/W~130Lm/W
- Power Efficiency: >90%
- Color Temperature: 3000~6500K
- Working Environment: -30°C~50°C
- IP Rating: IP68
- Installation Diameter: Φ60mm

**Eternal Dimension:**

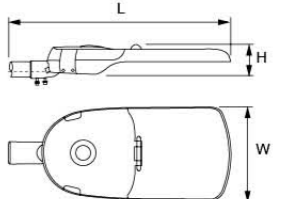

SIZE	L	W	H	Power
A	545	356	130	LED100W
B	625	356	130	LED150W
C	705	356	130	LED200W
D	785	356	130	LED250W-300W

**HD2062**



**Product Parameter:**

- Wattage Range: 60W-180W
- Efficiency: 120Lm/W~160Lm/W
- Power Efficiency: >90%
- Color Temperature: 3000~6500K
- Working Environment: -30°C~50°C
- IP Rating: IP68
- Installation Diameter: Φ60mm

**Eternal Dimension:**

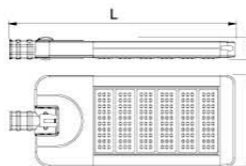

SIZE	L	W	H	Power
A	565	360	100	LED60W
B	650	360	100	LED90W
C	735	360	100	LED120W
D	820	360	100	LED150W
E	905	360	100	LED180W

**HD029**



**Product Parameter:**

- Wattage Range: 30W-180W
- Efficiency: 100Lm/W~130Lm/W
- Power Efficiency: >90%
- Color Temperature: 3000~6500K
- Working Environment: -30°C~50°C
- IP Rating: IP68
- Installation Diameter: Φ60mm

**Eternal Dimension:**

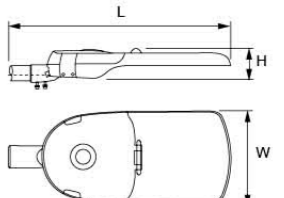

SIZE	L	W	H	Power
A	480	215	110	LED30W-50W
B	530	255	110	LED60W-80W
C	600	280	110	LED100W-120W
D	695	335	110	LED150W-180W



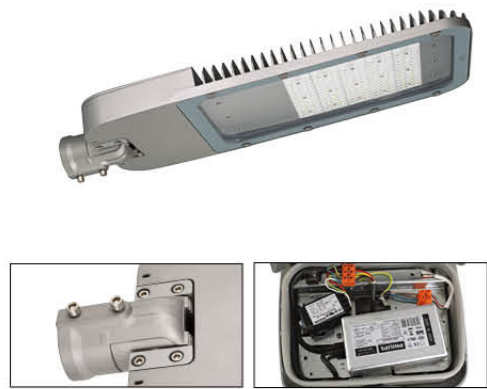

**HD010**



**Product Parameter:**

- Wattage Range: 60W-240W
- Efficiency: 100Lm/W~130Lm/W
- Power Efficiency: >90%
- Color Temperature: 3000~6500K
- Working Environment: -30°C~50°C
- IP Rating: IP68
- Installation Diameter: Φ60mm

**Eternal Dimension:**

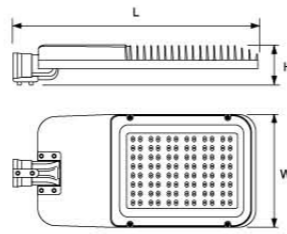

SIZE	L	W	H	Power
A	600	315	150	LED60W
B	800	315	150	LED240W



**HD009**



**Product Parameter:**

- Wattage Range: 60W-180W
- Efficiency: 100Lm/W~130Lm/W
- Power Efficiency: >90%
- Color Temperature: 3000~6500K
- Working Environment: -30°C~50°C
- IP Rating: IP68
- Installation Diameter: Φ60mm

**Eternal Dimension:**

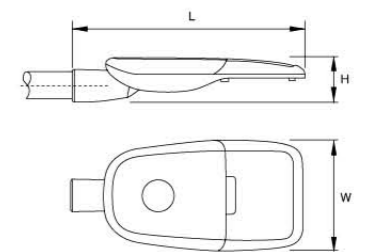

SIZE	L	W	H	Power
A	530	255	110	LED60W-80W
B	600	280	110	LED100W-120W
C	695	335	110	LED150W-180W



**HD004**



**Product Parameter:**

- Wattage Range: 60W-180W
- Efficiency: 100Lm/W~130Lm/W
- Power Efficiency: >90%
- Color Temperature: 3000~6500K
- Working Environment: -30°C~50°C
- IP Rating: IP68
- Installation Diameter: Φ60mm

**Eternal Dimension:**

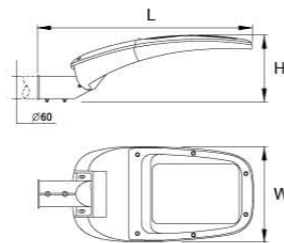

SIZE	L	W	H	Power
A	540	240	140	LED60W-80W
B	605	295	150	LED100W-120W
C	700	305	150	LED150W-180W



**HD022**



**Product Parameter:**

- Wattage Range: 60W-150W
- Efficiency: 100Lm/W~130Lm/W
- Power Efficiency: >90%
- Color Temperature: 3000~6500K
- Working Environment: -30°C~50°C
- IP Rating: IP68
- Installation Diameter: Φ60mm

**Eternal Dimension:**

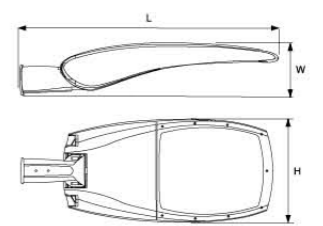

SIZE	L	W	H	Power
A	680	325	120	LED60W-90W
B	780	325	120	LED90W-150W



**HD526**



**Product Parameter:**

- Wattage Range: 60W-350W
- Efficiency: 100Lm/W~130Lm/W
- Power Efficiency: >90%
- Color Temperature: 3000~6500K
- Working Environment: -30°C~50°C
- IP Rating: IP68
- Installation Diameter: Φ60mm

**Eternal Dimension:**

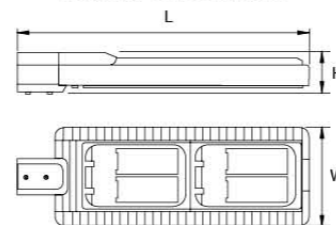

SIZE	L	W	H	Power
A	505	205	96	LED60W-90W
B	505	305	96	LED120W-180W
C	650	305	96	LED200W-250W
D	880	310	96	LED350W



**HD2016**



**Product Parameter:**

- Wattage Range: 40W-200W
- Efficiency: 100Lm/W~130Lm/W
- Power Efficiency: >90%
- Color Temperature: 3000~6500K
- Working Environment: -30°C~50°C
- IP Rating: IP68
- Installation Diameter: Φ60mm

**Eternal Dimension:**

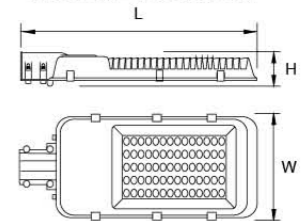

SIZE	L	W	H	Power
A	495	210	60	LED40W
B	600	250	75	LED80W
C	700	290	80	LED120W
D	800	300	80	LED150W
E	900	300	80	LED200W





**HD516**



**Product Parameter:**

- Wattage Range: 20W-180W
- Efficiency: 100Lm/W~130Lm/W
- Power Efficiency: >90%
- Color Temperature: 3000~6500K
- Working Environment: -30°C~50°C
- IP Rating: IP68
- Installation Diameter: Φ60mm

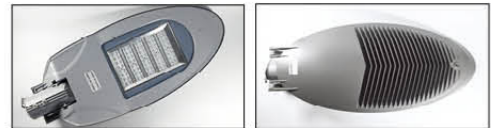

**Eternal Dimension:**

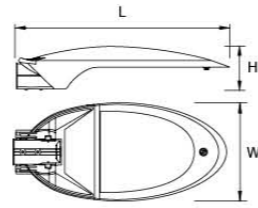

SIZE	L	W	H	Power
A	474	238	100	LED20W-60W
B	644	303	132	LED60W-90W
C	864	375	168	LED120W-180W



**HD035**



**Product Parameter:**

- Wattage Range: 20W-60W
- Efficiency: 100Lm/W~130Lm/W
- Power Efficiency: >90%
- Color Temperature: 3000~6500K
- Working Environment: -30°C~50°C
- IP Rating: IP68
- Installation Diameter: Φ60mm



**Eternal Dimension:**

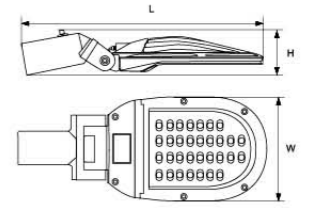

SIZE	L	W	H	Power
A	460	195	80	LED20W-30W
B	603	220	100	LED30W-60W



**HD517**



**Product Parameter:**

- Wattage Range: 80W-180W
- Efficiency: 100Lm/W~130Lm/W
- Power Efficiency: >90%
- Color Temperature: 3000~6500K
- Working Environment: -30°C~50°C
- IP Rating: IP68
- Installation Diameter: Φ60mm



**Eternal Dimension:**

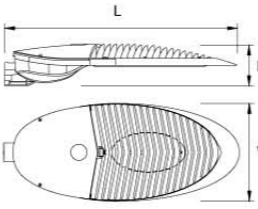

SIZE	L	W	H	Power
A	750	311	127	LED80W
B	950	400	145	LED180W



**HD005**



**Product Parameter:**

- Wattage Range: 60W-150W
- Efficiency: 100Lm/W~130Lm/W
- Power Efficiency: >90%
- Color Temperature: 3000~6500K
- Working Environment: -30°C~50°C
- IP Rating: IP68
- Installation Diameter: Φ60mm



**Eternal Dimension:**

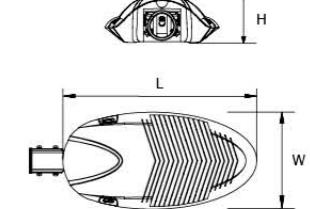

SIZE	L	W	H	Power
A	691	305	134	LED60W-150W



**HD527**



**Product Parameter:**

- Wattage Range: 20W-180W
- Efficiency: 100Lm/W~130Lm/W
- Power Efficiency: >90%
- Color Temperature: 3000~6500K
- Working Environment: -30°C~50°C
- IP Rating: IP68
- Installation Diameter: Φ60mm



**Eternal Dimension:**

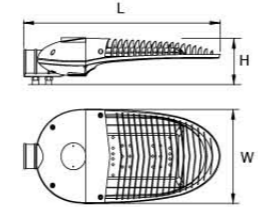

SIZE	L	W	H	Power
A	518	228	114	LED20W-50W
B	750	322	167	LED60W-90W
C	900	386	167	LED100W-180W



**HD036**



**Product Parameter:**

- Wattage Range: 60W-150W
- Efficiency: 100Lm/W~130Lm/W
- Power Efficiency: >90%
- Color Temperature: 3000~6500K
- Working Environment: -30°C~50°C
- IP Rating: IP68
- Installation Diameter: Φ60mm



**Eternal Dimension:**

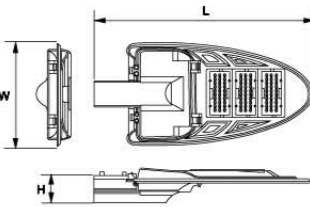

SIZE	L	W	H	Power
A	580	285	95	LED60W
B	690	342	100	LED150W





**HD037**



**Product Parameter:**

- Wattage Range: 20W-60W
- Efficiency: 100Lm/W~130Lm/W
- Power Efficiency: >90%
- Color Temperature: 3000~6500K
- Working Environment: -30°C~50°C
- IP Rating: IP68
- Installation Diameter: Φ60mm

**Eternal Dimension:**

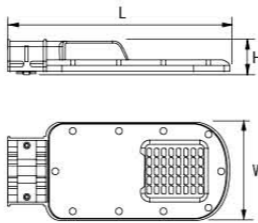

SIZE	L	W	H	Power
A	360	160	50	LED20W-40W
B	400	183	55	LED40W-60W



**HD209**



**Product Parameter:**

- Wattage Range: 20W-180W
- Efficiency: 100Lm/W~130Lm/W
- Power Efficiency: >90%
- Color Temperature: 3000~6500K
- Working Environment: -30°C~50°C
- IP Rating: IP68
- Installation Diameter: Φ60mm

**Eternal Dimension:**

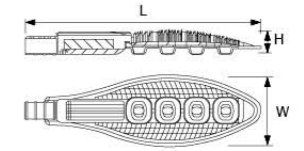

SIZE	L	W	H	Power
A	400	170	70	LED20W-30W
B	500	215	80	LED30W-60W
C	720	280	110	LED80W-120W
D	880	340	120	LED120W-180W

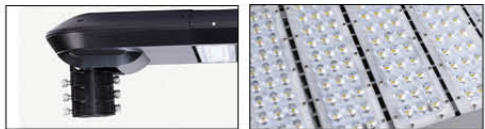

**HD017**



**Product Parameter:**

- Wattage Range: 100W-250W
- Efficiency: 120Lm/W~160Lm/W
- Power Efficiency: >90%
- Color Temperature: 3000~6500K
- Working Environment: -30°C~50°C
- IP Rating: IP68
- Installation Diameter: Φ60mm

**Eternal Dimension:**

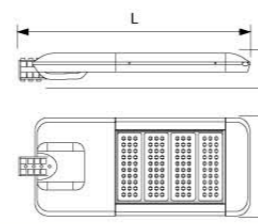

SIZE	L	W	H	Power
A	576	300	107	LED100W
B	657	300	107	LED150W
C	738	300	107	LED200W
D	819	300	107	LED250W



**HD202**



**Product Parameter:**

- Wattage Range: 30W-180W
- Efficiency: 100Lm/W~130Lm/W
- Power Efficiency: >90%
- Color Temperature: 3000~6500K
- Working Environment: -30°C~50°C
- IP Rating: IP68
- Installation Diameter: Φ60mm

**Eternal Dimension:**

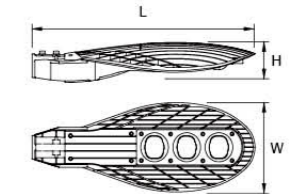

SIZE	L	W	H	Power
A	540	250	110	LED30W-60W
B	600	245	105	LED60W-120W
C	800	305	136	LED90W-180W



**HD027**



**Product Parameter:**

- Wattage Range: 20W-80W
- Efficiency: 100Lm/W~130Lm/W
- Power Efficiency: >90%
- Color Temperature: 3000~6500K
- Working Environment: -30°C~50°C
- IP Rating: IP68
- Installation Diameter: Φ60mm

**Eternal Dimension:**

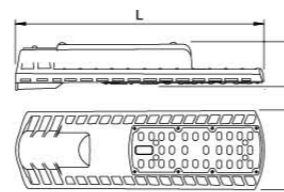

SIZE	L	W	H	Power
A	395	110	75	LED20W-40W
B	490	155	80	LED30W-80W



**HD212**



**Product Parameter:**

- Wattage Range: 30W-180W
- Efficiency: 100Lm/W~130Lm/W
- Power Efficiency: >90%
- Color Temperature: 3000~6500K
- Working Environment: -30°C~50°C
- IP Rating: IP68
- Installation Diameter: Φ60mm

**Eternal Dimension:**

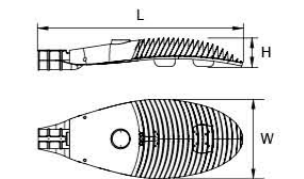

SIZE	L	W	H	Power
A	400	170	75	LED30W
B	535	218	96	LED60W-80W
C	756	296	120	LED120W
D	880	340	122	LED180W



HD-Y001 Series



**Applications**

Road, street, gardens, parks, parking lots, resident areas like villa and apartment or house.

**Features**

- Modern fashion design of appearance, excellent self-cleaning capability.
- High strength aluminum die casting material, surface anti-ageing electrostatic spray process.
- PC diffuser, high strength impact resistance.
- Branded LED chips(Epistar, Cree) and reliable long life driver provide quality lighting ;
- Input voltage: AC110-277V, 50/60Hz, IP65, IK08



**Size(mm)**

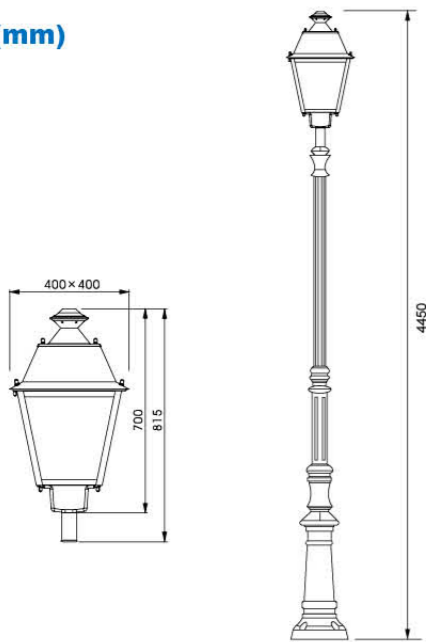

**Specification**

产品型号	Product Code	HD-Y001	HD-Y001	HD-Y001	HD-Y001
额定功率	Rated Power	20W	40W	60W	90W
色温	CCT	3000K-6500K	3000K-6500K	3000K-6500K	3000K-6500K
初始光通量	Luminous Flux	110LM/W	110LM/W	110LM/W	110LM/W
安装孔径	Installation Diameter	Φ60mm	Φ60mm	Φ60mm	Φ60mm
安装高度	Installation Height	3-6m	3-6m	3-6m	3-6m
产品尺寸 (mm)	Product Size	400*400*700	400*400*700	400*400*700	400*400*700
净重	N.W	5KGS	5.5KGS	6KGS	6.5KGS
防护等级	IP Grade	IP66	IP66	IP66	IP66

HD-Y003 Series



**Applications**

Road, street, gardens, parks, parking lots, resident areas like villa and apartment or house.

**Features**

- Modern fashion design of appearance, excellent self-cleaning capability.
- High strength aluminum die casting material, surface anti-ageing electrostatic spray process.
- PC diffuser, high strength impact resistance.
- Branded LED chips(Epistar, Cree) and reliable long life driver provide quality lighting ;
- Input voltage: AC110-277V, 50/60Hz, IP65, IK08

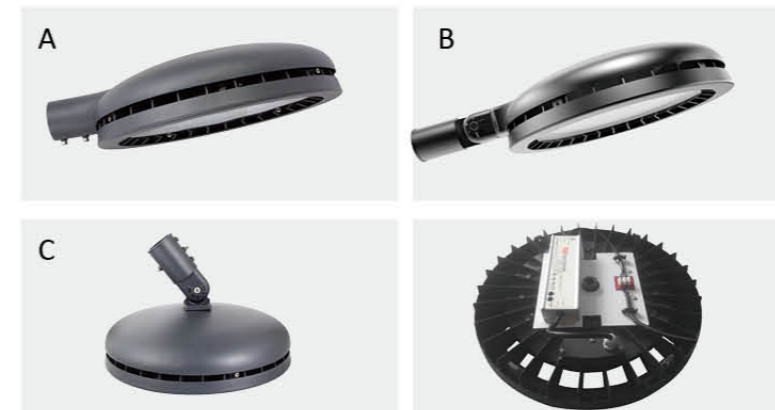

**Size(mm)**

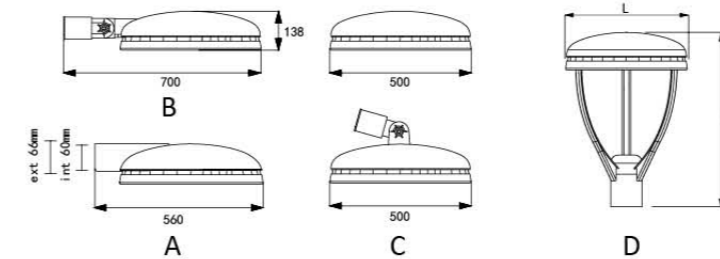

**Specification**

产品型号	Product Code	HD-Y003A	HD-Y003B	HD-Y003C	HD-Y003D
额定功率	Rated Power	60W-150W	60W-150W	60W-150W	60W-150W
色温	CCT	3000K-6500K	3000K-6500K	3000K-6500K	3000K-6500K
初始光通量	Luminous Flux	110LM/W	110LM/W	110LM/W	110LM/W
安装孔径	Installation Diameter	Φ60mm	Φ60mm	Φ60mm	Φ76mm
净重 / 毛重	N.W./G.W.	2KGS/2.5KGS	3KGS/4KGS	4.1KGS/5.2KGS	7KGS/8.5KGS
产品尺寸 (mm)	Product Size	608*500*138	700*500*138	500*500*238	500*500*640
防护等级	IP Grade	IP65	IP65	IP65	IP65

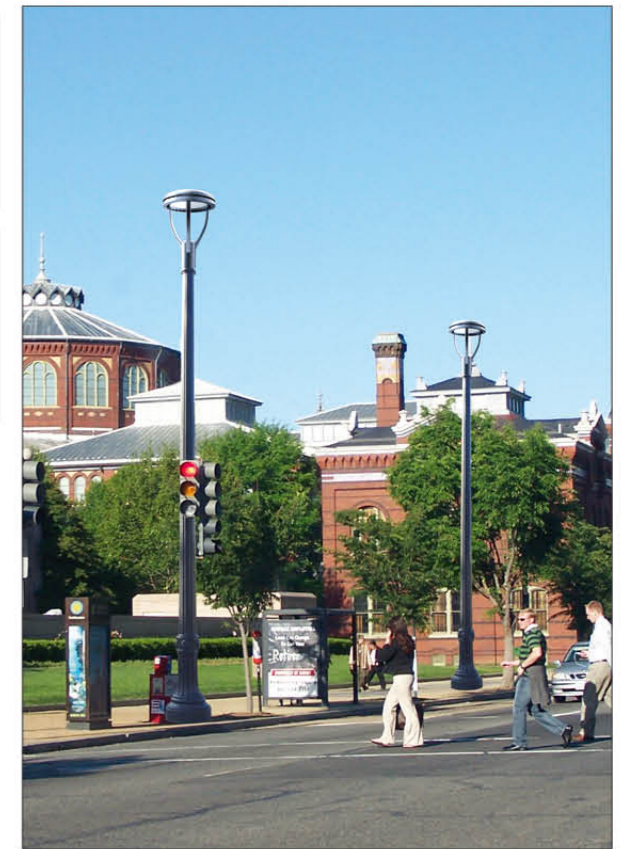



HD-Y032 Series



Size(mm)

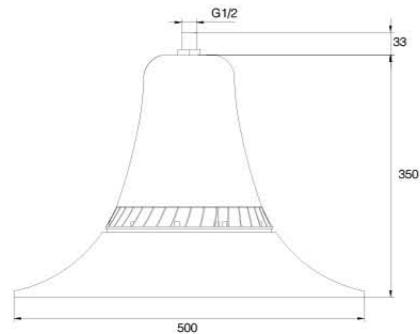

Applications

Road, street, gardens, parks, parking lots, resident areas like villa and apartment or house.

Features

- Modern fashion design of appearance, excellent self-cleaning capability.
- High strength aluminum die casting material, surface anti-ageing electrostatic spray process.
- PC diffuser, high strength impact resistance.
- Branded LED chips(Epistar, Cree) and reliable long life driver provide quality lighting ;
- Input voltage: AC110-277V, 50/60Hz, IP65, IK08



Specification

产品型号	Product Code	HD-Y032	HD-Y032	HD-Y032
额定功率	Rated Power	30W	60W	100W
色温	CCT	3000K-6500K	3000K-6500K	3000K-6500K
初始光通量	Luminous Flux	110LM/W	110LM/W	110LM/W
安装高度	Installation Height	3-6m	3-6m	3-6m
产品尺寸 ( mm )	Product Size	450*480*525	450*480*525	450*480*525
防护等级	IP Grade	IP66	IP66	IP66

HD-Y021 Series



Size(mm)

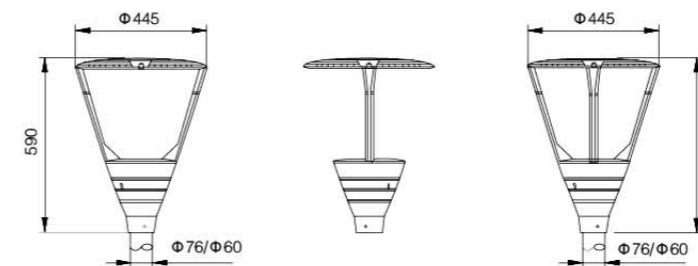

Light Distrebuton Curve

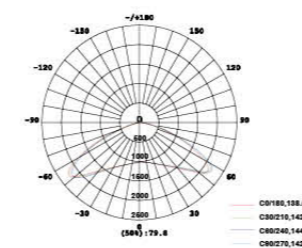

Specification

产品型号	Product Code	HD-Y021	HD-Y021	HD-Y021	HD-Y021
额定功率	Rated Power	30W	40W	60W	80W
色温	CCT	3000K-6500K	3000K-6500K	3000K-6500K	3000K-6500K
初始光通量	Luminous Flux	110LM/W	110LM/W	110LM/W	110LM/W
安装孔径	Installation Diameter	Φ76/60mm	Φ76/60mm	Φ76/60mm	Φ76/60mm
净重 / 毛重	N.W./G.W.	8.1KGS/9KGS	8.2KGS/9.2KGS	8.3KGS/9.3KGS	8.4KGS/9.4KGS
产品尺寸 ( mm )	Product Size	445*445*590	445*445*590	445*445*590	445*445*590
包装尺寸 ( mm )	Packing Size	445*455*610	445*455*610	445*455*610	445*455*610

Applications

Road, street, gardens, parks, parking lots, resident areas like villa and apartment or house.

Features

- Modern fashion design of appearance, excellent self-cleaning capability.
- High strength aluminum die casting material, surface anti-ageing electrostatic spray process.
- PC diffuser, high strength impact resistance.
- Branded LED chips(Epistar, Cree) and reliable long life driver provide quality lighting ;
- Input voltage: AC110-277V, 50/60Hz, IP65, IK08





HD-Y004 Series



**Applications**

Road, street, gardens, parks, parking lots, resident areas like villa and apartment or house.

**Features**

- Modern fashion design of appearance, excellent self-cleaning capability.
- High strength aluminum die casting material, surface anti-ageing electrostatic spray process.
- PC diffuser, high strength impact resistance.
- Branded LED chips(Epistar, Cree) and reliable long life driver provide quality lighting ;
- Input voltage: AC110-277V, 50/60Hz, IP65, IK08

**Size(mm)**

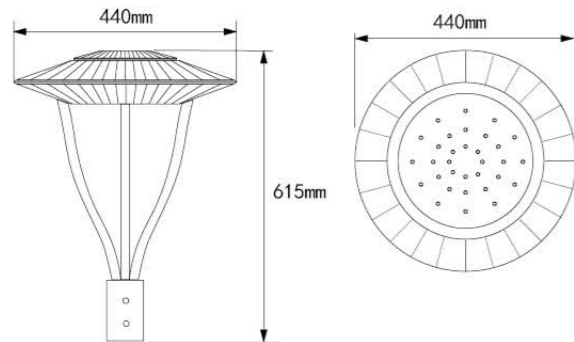

**Specification**

产品型号	Product Code	HD-Y004	HD-Y004	HD-Y004
额定功率	Rated Power	30W	60W	100W
色温	CCT	3000K-6500K	3000K-6500K	3000K-6500K
初始光通量	Luminous Flux	110LM/W	110LM/W	110LM/W
安装孔径	Installation Diameter	Φ60 / Φ76mm	Φ60 / Φ76mm	Φ60 / Φ76mm
安装高度	Installation Height	3-6m	3-6m	3-6m
产品尺寸 ( mm )	Product Size	450*480*525	450*480*525	450*480*525
防护等级	IP Grade	IP66	IP66	IP66

HD-Y033 Series



**Applications**

Road, street, gardens, parks, parking lots, resident areas like villa and apartment or house.

**Features**

- Modern fashion design of appearance, excellent self-cleaning capability.
- High strength aluminum die casting material, surface anti-ageing electrostatic spray process.
- PC diffuser, high strength impact resistance.
- Branded LED chips(Epistar, Cree) and reliable long life driver provide quality lighting ;
- Input voltage: AC110-277V, 50/60Hz, IP65, IK08

**Size(mm)**



**Specification**

产品型号	Product Code	HD-Y033	HD-Y033	HD-Y033
额定功率	Rated Power	30W	60W	100W
色温	CCT	3000K-6500K	3000K-6500K	3000K-6500K
初始光通量	Luminous Flux	110LM/W	110LM/W	110LM/W
安装孔径	Installation Diameter	Φ60 / Φ70mm	Φ60 / Φ70mm	Φ60 / Φ70mm
安装高度	Installation Height	3-6m	3-6m	3-6m
产品尺寸 ( mm )	Product Size	450*480*525	450*480*525	450*480*525
防护等级	IP Grade	IP66	IP66	IP66



HD-Y007 Series



**Applications**

Road, street, gardens, parks, parking lots, resident areas like villa and apartment or house.

**Features**

- Modern fashion design of appearance, excellent self-cleaning capability.
- High strength aluminum die casting material, surface anti-ageing electrostatic spray process.
- Supper white toughened glass, sealed lamp housing.
- Branded LED chips(Epistar, Cree) and reliable long life driver provide quality lighting ;
- Input voltage: AC110-277V, 50/60Hz, IP65, IK08

**Size(mm)**

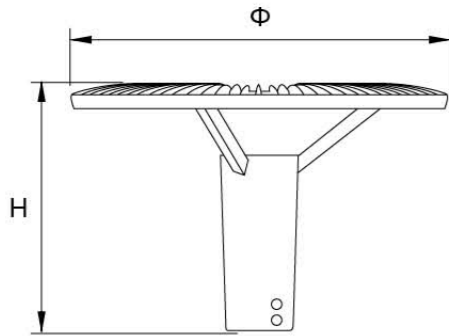

**Specification**

产品型号	Product Code	HD-Y007	HD-Y007
额定功率	Rated Power	30W	60W
色温	CCT	3000K-6600K	3000K-6600K
初始光通量	Luminous Flux	110LM/W	110LM/W
安装孔径	Installation Diameter	Φ60mm	Φ60mm
净重 / 毛重	N.W./G.W.	6.55KGS/7.8KGS	8.1KGS/9KGS
产品尺寸 ( mm )	Product Size	598*598*391	598*598*391

HD-Y034 Series



**Applications**

Road, street, gardens, parks, parking lots, resident areas like villa and apartment or house.

**Features**

- Modern fashion design of appearance, excellent self-cleaning capability.
- High strength aluminum die casting material, surface anti-ageing electrostatic spray process.
- Supper white toughened glass, sealed lamp housing.
- Branded LED chips(Epistar, Cree) and reliable long life driver provide quality lighting ;
- Input voltage: AC110-277V, 50/60Hz, IP65, IK08



**Specification**

产品型号	Product Code	HD-Y034	HD-Y034	HD-Y034	HD-Y034
额定功率	Rated Power	60W-150W	60W-150W	60W-150W	60W-150W
色温	CCT	3000K-6500K	3000K-6500K	3000K-6500K	3000K-6500K
初始光通量	Luminous Flux	110LM/W	110LM/W	110LM/W	110LM/W
安装孔径	Installation Diameter	Φ89mm	Φ89mm	Φ89mm	Φ89mm
安装高度	Installation Height	3-6m	3-6m	3-6m	3-6m
产品尺寸 ( mm )	Product Size	396*396*1706	396*396*1706	396*396*1706	396*396*1706
防护等级	IP Grade	IP65	IP65	IP65	IP65



HD-Y035 Series



**Applications**

Road, street, gardens, parks, parking lots, resident areas like villa and apartment or house.

**Features**

- Modern fashion design of appearance, excellent self-cleaning capability.
- High strength aluminum die casting material, surface anti-ageing electrostatic spray process.
- Supper white toughened glass, sealed lamp housing.
- Branded LED chips(Epistar, Cree) and reliable long life driver provide quality lighting ;
- Input voltage: AC110-277V, 50/60Hz, IP65, IK08



**Specification**

产品型号	Product Code	HD-Y035	HD-Y035
额定功率	Rated Power	30W	60W
色温	CCT	3000K-6600K	3000K-6600K
初始光通量	Luminous Flux	110LM/W	110LM/W
安装孔径	Installation Diameter	Φ76mm	Φ76mm
净重 / 毛重	N.W./G.W.	6.55KGS/7.8KGS	8.1KGS/9KGS
产品尺寸 ( mm )	Product Size	660*660*400	660*660*400

HD-Y019

**Features**

Modern fashion design of appearance, excellent self-cleaning capability.

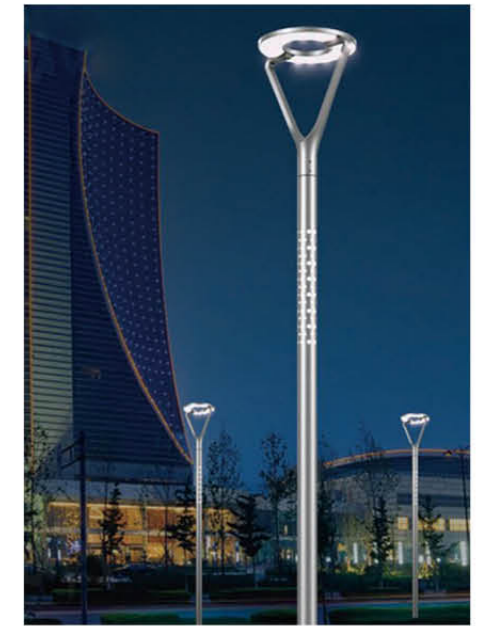

Model	LED	Power(w)	Luminous(lm)	Luminous Efficiency(lm/w)	IP Grade	Install The Diameter	Installation Height	Product Size(mm)
HD-Y019	SMD	40W	4400	110	IP65	Φ89mm	3-6m	633*560*795

HD-Y036

**Features**

High strength aluminum die casting material, surface anti-ageing electrostatic spray process.



**Specification**

Model	LED	Power(w)	Luminous(lm)	Luminous Efficiency(lm/w)	IP Grade	Install The Diameter	Installation Height	Product Size(mm)
HD-Y036	SMD	40W	4400	110	IP65	Φ76mm	3-6m	633*560*795



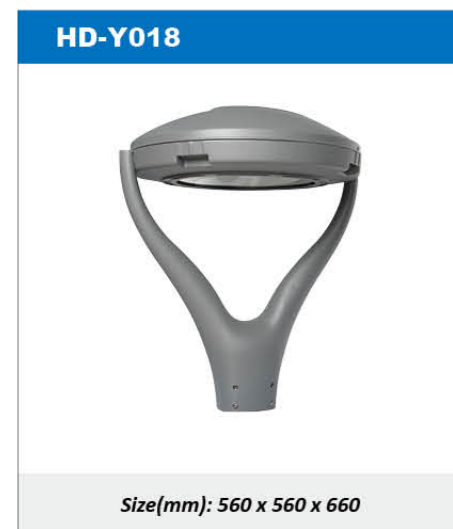
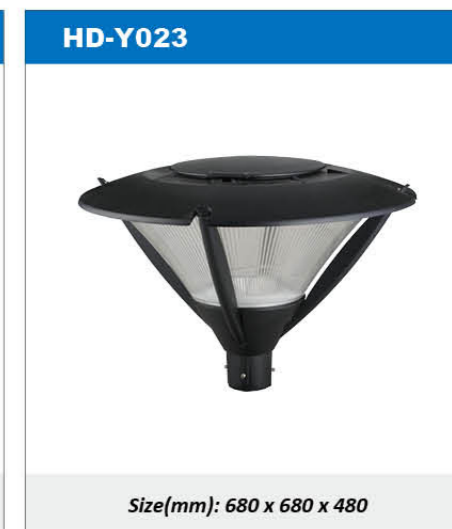
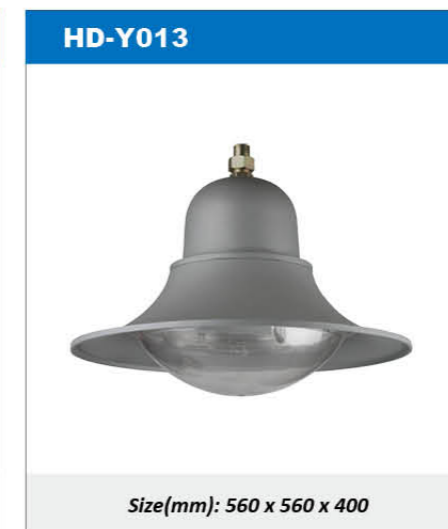
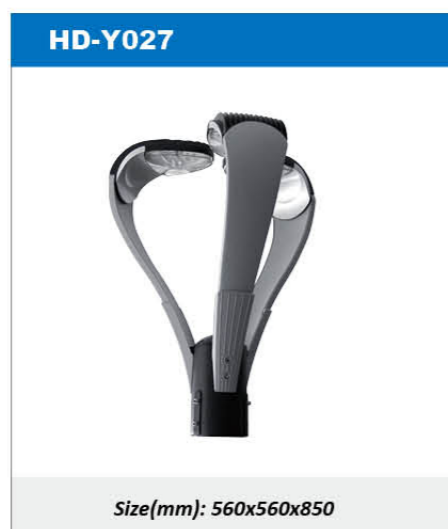
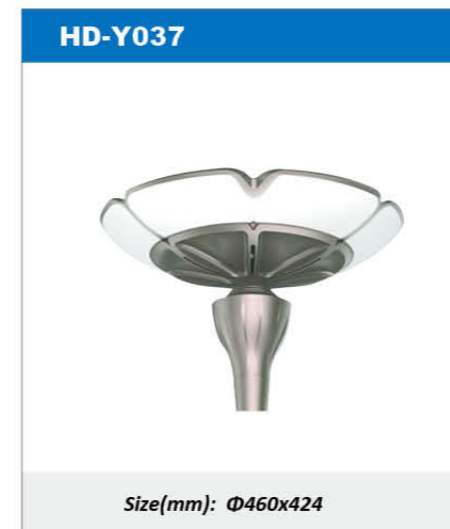
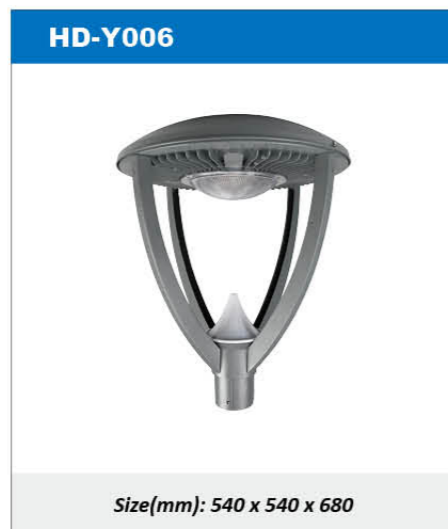
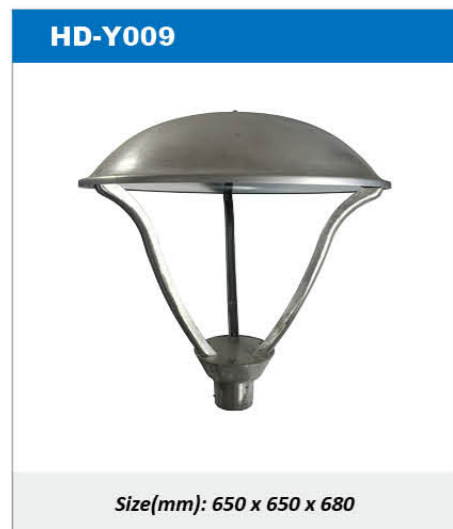



HD-F021 Series

10%~90%  
 +50°C ~ -35°C  
 50,000h  
**CRI** >75  
**PF** >0.95  
 AC85-265V

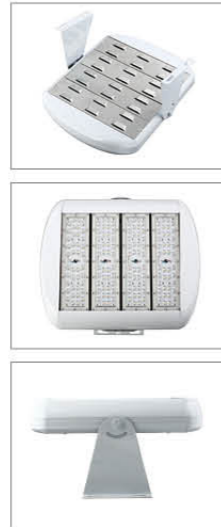

**Applications**

High mast light, tunnel, ware house, supermarket, factory, Large store, freezer room and so on.

**Features**

- Strong lamp body with die-cast aluminum alloy and easy installation bracket.
- Lamp shade following fluid dynamic principles, avoid dust.
- Module design offers more selections for different application, helps cooling LEDs and improves the lamp life.
- Counter flow design for cooling.
- Unique dust-cover plate;
- Portable driver pack, easy for installation and maintenance.
- IP67 for LED module, ASTM6063 radiating block, black anodic oxidation treatment on surface, micro Cooling treatment for heat fins.

**Other Option**



HD-F508



HD-F007

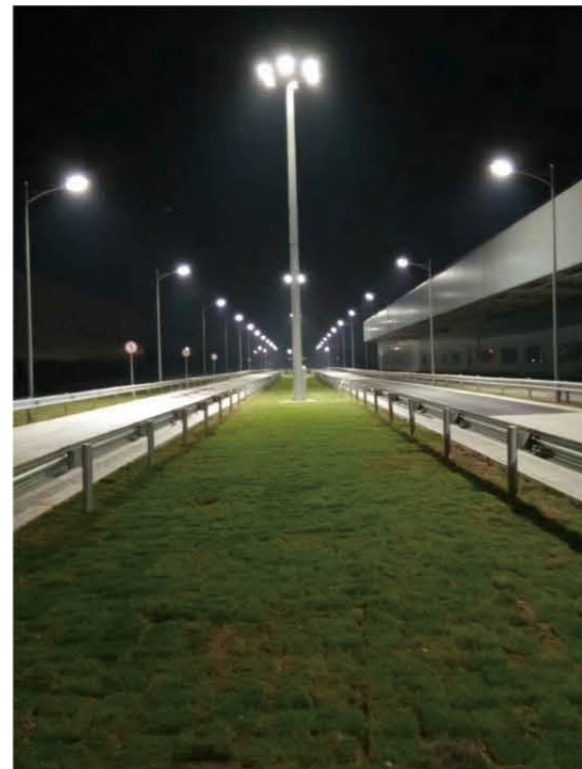

**Specification**

产品型号	Product Code	HD-FD021	HD-FD021	HD-FD021	HD-FD021
额定功率	Rated Power	100W	150W	200W	250W
色温	CCT	3000K-6500K	3000K-6500K	3000K-6500K	3000K-6500K
初始光通量	Luminous Flux	110LM/W	110LM/W	110LM/W	110LM/W
功率因素	Power Factor	>0.95	>0.95	>0.95	>0.95
输入电压	Input Voltage	100-240V	100-240V	100-240V	100-240V
产品尺寸 (mm)	Product Size	235*310*72	310*310*72	385*350*72	460*350*72
防护等级	IP Grade	IP68	IP68	IP68	IP68

HD-F017 Series

10%~90%  
 +50°C ~ -35°C  
 50,000h  
**CRI** >75  
**PF** >0.95



**Applications**

Baseball stadium, football stadium, tennis court lighting applications utilizing advance LED reflective optical system.

**Features**

- High strength aluminum die casting material, surface anti-ageing electrostatic spraying processing, super resistance to corrosion.
- Mounting options: Trunnion & Knuckle.
- High light transmittance optical lens and tempered glassed.
- Utilizes high brightness LEDs, 80 CRI at 3000K, 4000K and 6500K typical.



**Specification**

Model	Product Size(mm)	Power(w)	Input Voltage	Luminous(lm)	Luminous Efficiency(lm/w)	IP Grade	Power Factor	CRI	Beam Angle
HD-F017	130*332*150	50W	100-240V	6000	120	IP65	>0.95	70/80	20°/30°/45°/60°/90°/120°
HD-F017	265*332*150	100W	100-240V	12000	120	IP65	>0.95	70/80	20°/30°/45°/60°/90°/120°
HD-F017	400*332*165	150W	100-240V	18000	120	IP65	>0.95	70/80	20°/30°/45°/60°/90°/120°
HD-F017	535*332*150	200W	100-240V	24000	120	IP65	>0.95	70/80	20°/30°/45°/60°/90°/120°
HD-F017	130*640*150	100W	100-240V	6000	120	IP65	>0.95	70/80	20°/30°/45°/60°/90°/120°
HD-F017	265*640*150	200W	100-240V	24000	120	IP65	>0.95	70/80	20°/30°/45°/60°/90°/120°
HD-F017	400*640*130	300W	100-240V	36000	120	IP65	>0.95	70/80	20°/30°/45°/60°/90°/120°
HD-F017	535*640*130	400W	100-240V	48000	120	IP65	>0.95	70/80	20°/30°/45°/60°/90°/120°
HD-F017	670*640*130	500W	100-240V	60000	120	IP65	>0.95	70/80	20°/30°/45°/60°/90°/120°
HD-F017	805*640*150	600W	100-240V	72000	120	IP65	>0.95	70/80	20°/30°/45°/60°/90°/120°



## HD-F024 Series

### Applications

High mast light, tunnel, ware house, supermarket, factory, Large store, freezer room and so on.

### Features

- Strong lamp body with die-cast aluminum alloy and easy installation bracket.
- Lamp shade following fluid dynamic principles, avoid dust.
- Module design offers more selections for different application, helps cooling LEDs and improves the lamp life.
- Counter flow design for cooling; Unique dust-cover plate;
- Portable driver pack, easy for installation and maintenance.

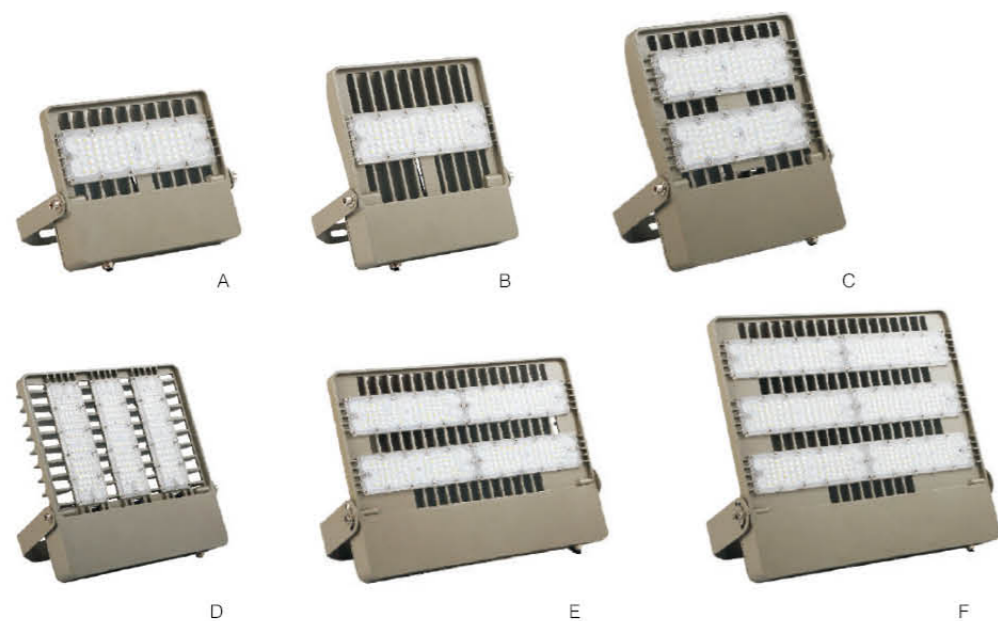

### Specification

产品型号	Product Code	HD-F024A	HD-F024B	HD-F024C
额定功率	Rated Power	50W	65W	100W
芯片	Chips	NICHIA/LUMILEDS/CREE	NICHIA/LUMILEDS/CREE	NICHIA/LUMILEDS/CREE
灯珠数量	LED QTY(pcs)	64	64	128
光通量	Luminous Flux	120LM/W	120LM/W	120LM/W
显指	CRI	≥ 70	≥ 70	≥ 70
发光角度	Beam Angle	30°/60°/90°/120°	30°/60°/90°/120°	30°/60°/90°/120°
电压	Voltage	85-277V	85-277V	85-277V
净重	N.W	2.1KGS	2.7KGS	4.9KGS
产品尺寸 ( mm )	Product Size	280*280*47	280*350*47	300*390*54

产品型号	Product Code	HD-F024D	HD-F024E	HD-F024F
额定功率	Rated Power	150W	200W	300W
芯片	Chips	NICHIA/LUMILEDS/CREE	NICHIA/LUMILEDS/CREE	NICHIA/LUMILEDS/CREE
灯珠数量	LED QTY(pcs)	192	256	384
光通量	Luminous Flux	120LM/W	120LM/W	120LM/W
显指	CRI	≥ 70	≥ 70	≥ 70
发光角度	Beam Angle	30°/60°/90°	30°/60°/90°/90°/120°	30°/60°/90°/90°/120°
电压	Voltage	85-277V	85-277V	85-277V
净重	N.W	6.0KGS	8.7KGS	11.28KGS
产品尺寸 ( mm )	Product Size	390*445*60	510*440*60	510*530*60

## HD-F025 Series

### Applications

High mast light, tunnel, ware house, supermarket, factory, Large store, freezer room and so on.

### Features

- Strong lamp body with die-cast aluminum alloy and easy installation bracket.
- Lamp shade following fluid dynamic principles, avoid dust.
- Module design offers more selections for different application, helps cooling LEDs and improves the lamp life.
- Counter flow design for cooling; Unique dust-cover plate;
- Portable driver pack, easy for installation and maintenance.

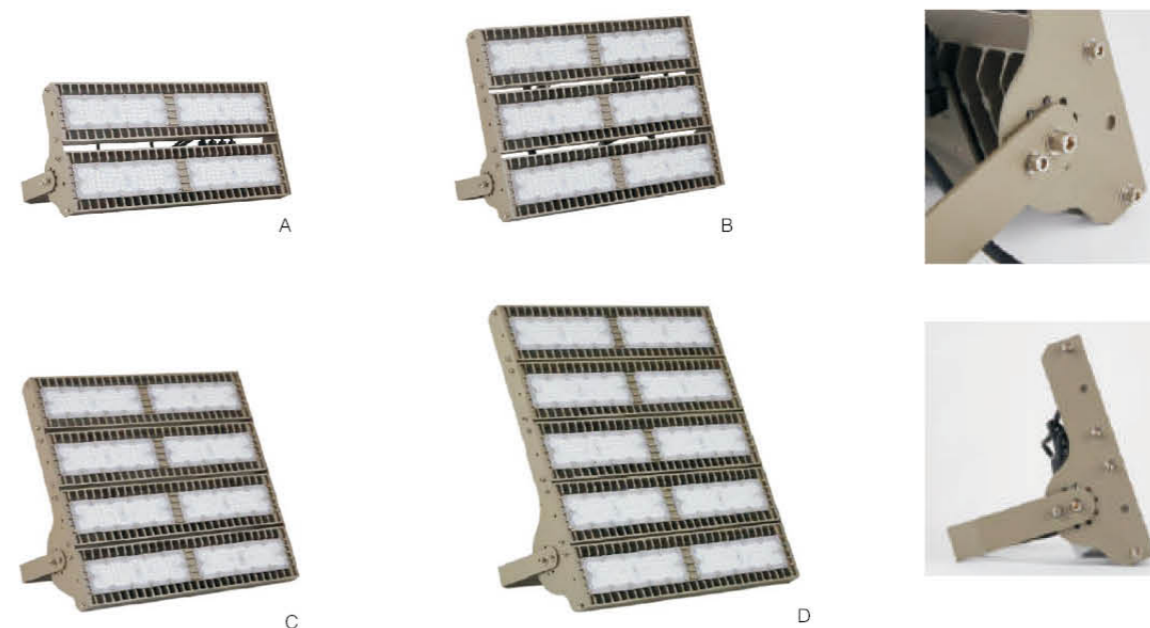

### Specification

产品型号	Product Code	HD-F025A	HD-F025B	HD-F025C	HD-F025D
额定功率	Rated Power	200W	300W	400W	500W
芯片	Chips	NICHIA/LUMILEDS/CREE	NICHIA/LUMILEDS/CREE	NICHIA/LUMILEDS/CREE	NICHIA/LUMILEDS/CREE
灯珠数量	LED QTY(pcs)	256	384	512	640
光通量	Luminous Flux	120LM/W	120LM/W	120LM/W	120LM/W
显指	CRI	≥ 70	≥ 70	≥ 70	≥ 70
发光角度	Beam Angle	30°/60°/90°/90°/120°	30°/60°/90°/90°/120°	30°/60°/90°/90°/120°	30°/60°/90°/90°/120°
电压	Voltage	85-277V	85-277V	85-277V	85-277V
净重	N.W	8.29KGS	13.38KGS	17.06KGS	20.06KGS
产品尺寸 ( mm )	Product Size	538*260*100	540*380*100	539*504*125	540*620*125



### HD-F026 Series

10%~90%	+50°C ~ -35°C	50,000h	<b>CRI</b> >75	<b>PF</b> >0.95
---------	---------------	---------	----------------	-----------------

#### Applications

Ware house, supermarkets, factories, large stores, freezer rooms and so on.

#### Features

- Three different methods of brackets installation
- High light transmittance optical lens and tempered glassed.
- Professional light distribution design.



#### Size(mm)

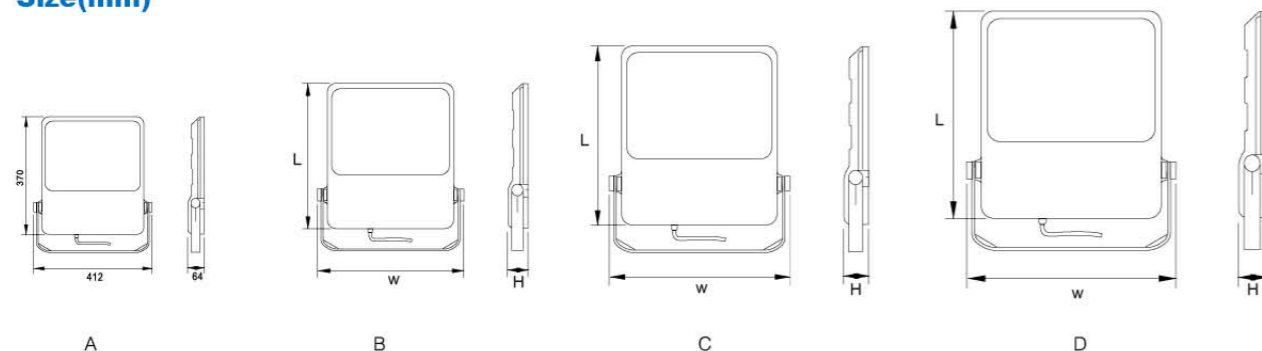

#### Specification

产品型号	Product Code	HD-F026A	HD-F026B	HD-F026C	HD-F026D
额定功率	Rated Power	100W	200W	300W	500W
色温	CCT	3000K-6500K	3000K-6500K	3000K-6500K	3000K-6500K
初始光通量	Luminous Flux	120LM/W	120LM/W	120LM/W	120LM/W
功率因素	Power Factor	>0.95	>0.95	>0.95	>0.95
输入电压	Input Voltage	100-240V	100-240V	100-240V	100-240V
产品尺寸 (mm)	Product Size	280*243*52	293*368*63	333*417*67	476*535*69
防护等级	IP Grade	IP68	IP68	IP68	IP68

### HD-F022 Series

10%~90%	+50°C ~ -35°C	50,000h	<b>CRI</b> >75	<b>PF</b> >0.95
---------	---------------	---------	----------------	-----------------

#### Applications

Ware house, supermarkets, factories, large stores, freezer rooms and so on.

#### Features

- Three different methods of brackets installation
- High light transmittance optical lens and tempered glassed.
- Professional light distribution design.

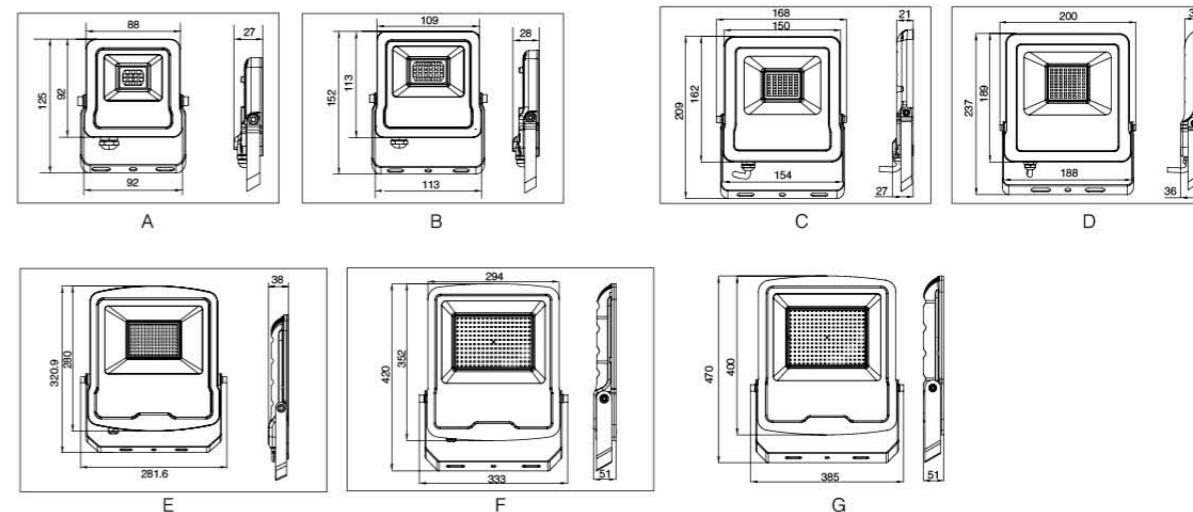

#### Specification

产品型号	Product Code	HD-F023A	HD-F023B	HD-F023C	HD-F023D
额定功率	Rated Power	10W	20W	30W	50W
光源类型 / 数量	Light Source/Numbers	2835/14	2835/28	2835/42	2835/70
色温	CCT	3000K-6500K	3000K-6500K	3000K-6500K	3000K-6500K
初始光通量	Luminous Flux	120LM/W	120LM/W	120LM/W	120LM/W
发光角度	Beam Angle	120°	120°	120°	120°
净重 / 毛重	N.W./G.W.	0.21KGS/0.26KGS	0.29KGS/0.35KGS	0.51KGS/0.57KGS	0.89KGS/0.95KGS
产品尺寸 (mm)	Product Size	125*27*104	152*125*28	168*209*27	200*237*36
内包装尺寸 (mm)	Inner packing Size	109*32*123	152*125*28	168*209*27	200*237*36
外包装尺寸 (mm)	Outer Packing Size	315*235*265	410*185*305	360*180*305	435*335*265
外包装产品数量	Numbers packed in one outer box	36	30	20	12

产品型号	Product Code	HD-F023E	HD-F023F	HD-F023G
额定功率	Rated Power	100W	150W	200W
光源类型 / 数量	Light Source/Numbers	2835/140	2835/210	2835/252
色温	CCT	3000K-6500K	3000K-6500K	3000K-6500K
初始光通量	Luminous Flux	120LM/W	120LM/W	120LM/W
发光角度	Beam Angle	120°	120°	120°
净重 / 毛重	N.W./G.W.	1.72KGS/2.08KGS	3.3KGS/3.8KGS	4.7KGS/5.7KGS
产品尺寸 (mm)	Product Size	281.6*320.9*38	420*333*51	470*385*51
内包装尺寸 (mm)	Inner packing Size	311*68*355	377*102*475	429*102*524
外包装尺寸 (mm)	Outer Packing Size	325*295*375	390*325*495	445*220*545
外包装产品数量	Numbers packed in one outer box	4	3	2



HD-F018 Series



10%~90%	+50°C -35°C	50,000h	<b>CRI</b> >75	<b>PF</b> >0.95
---------	----------------	---------	----------------	-----------------

**Applications**

Ware house, supermarkets, factories, large stores, gas station, freezer rooms and so on

**Features**

- Die-casting aluminum heat sink.
- Multi methods of installation.
- Much higher CRI to HPS LPS MH.
- Various beam angle.
- Dimming control available.
- IK08.



**Size(mm)**

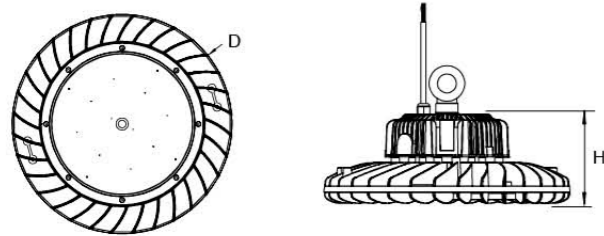

**Specification**

产品型号	Product Code	HD-FD018	HD-FD018	HD-FD018	HD-FD018	HD-FD018
额定功率	Rated Power	100W	120W	150W	180W	200W
色温	CCT	3000K-6500K	3000K-6500K	3000K-6500K	3000K-6500K	3000K-6500K
初始光通量	Luminous Flux	120LM/W	120LM/W	120LM/W	120LM/W	120LM/W
功率因素	Power Factor	>0.95	>0.95	>0.95	>0.95	>0.95
输入电压	Input Voltage	100-240V	100-240V	100-240V	100-240V	100-240V
产品尺寸 (mm)	Product Size	300*300*135	300*640*135	340*340*135	380*380*140	480*480*140
防护等级	IP Grade	IP65	IP65	IP65	IP65	IP65

HD-F022 Series



10%~90%	+50°C -35°C	50,000h	<b>CRI</b> >75	<b>PF</b> >0.95
---------	----------------	---------	----------------	-----------------

**Applications**

Ware house, supermarkets, factories, large stores, gas station, freezer rooms and so on

**Features**

- Die-casting aluminum heat sink.
- Multi methods of installation.
- Much higher CRI .
- IK08.

**Size(mm)**

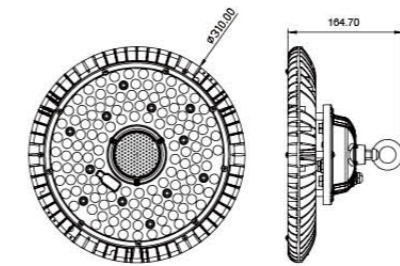

100W,120W

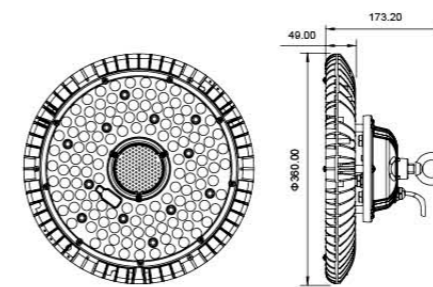

150W,200W

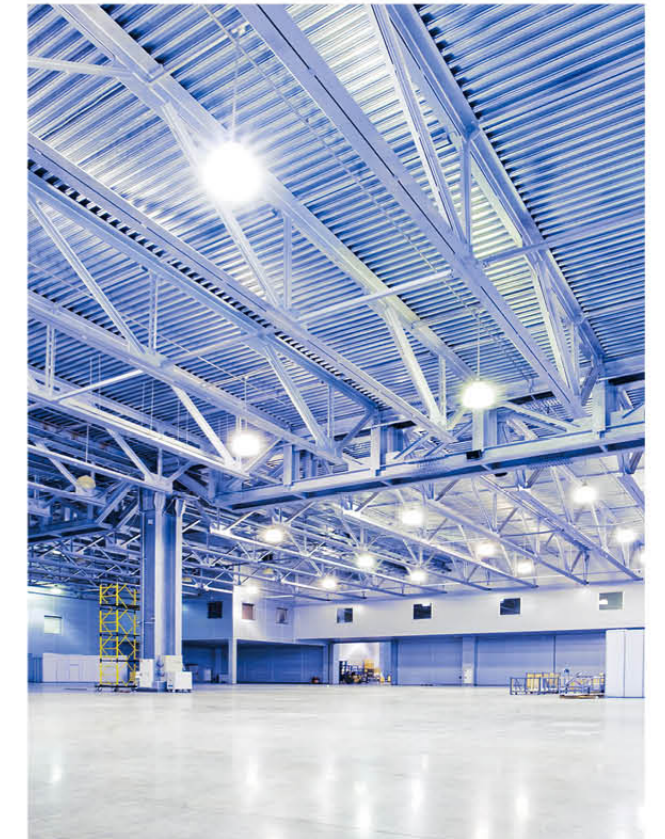

**Specification**

产品型号	Product Code	HD-F022A	HD-F022A	HD-F022B	HD-F022B
额定功率	Rated Power	100W	120W	150W	200W
光源类型 / 数量	Light Source/Numbers	2835/132	2835/180	2835/198	2835/300
色温	CCT	3000K-6500K	3000K-6500K	3000K-6500K	3000K-6500K
初始光通量	Luminous Flux	120LM/W	120LM/W	120LM/W	120LM/W
工作电压	Working Voltage	AC220-240V/50-60Hz	AC220-240V/50-60Hz	AC220-240V/50-60Hz	AC220-240V/50-60Hz
发光角度	Beam Angle	80° /100°	80° /100°	80° /100°	80° /100°
净重 / 毛重	N.W./G.W.	2.68KGS/3.08KGS	2.68KGS/3.08KGS	4.0KGS/4.42KGS	4.0KGS/4.42KGS
产品尺寸 (mm)	Product Size	Φ310*164.7	Φ310*164.7	Φ360*173.2	Φ360*173.2
包装尺寸 (mm)	Packing Size	350*350*170	350*350*170	405*405*177	405*405*177



# Intergrated Solar Street Light



HD032

## Advantages

- Easy Installation: Just Plug 1 Cable and your system is ready to proceed
- Light Weight: which saves a lot in the lighting Poles specifications and cost
- Longer Life Span: 1.5 times more life span than GEL batteries with higher DOD percentage
- More Decorative: Aluminum case with digital indicators makes it more convenient for street light decorative designs
- Transportation Cost Saving: smaller in size and lighter in weight means less space in container loading
- Adjustable Working Modes: wit remote control option
- Rust Proof: Aluminum casing never rust

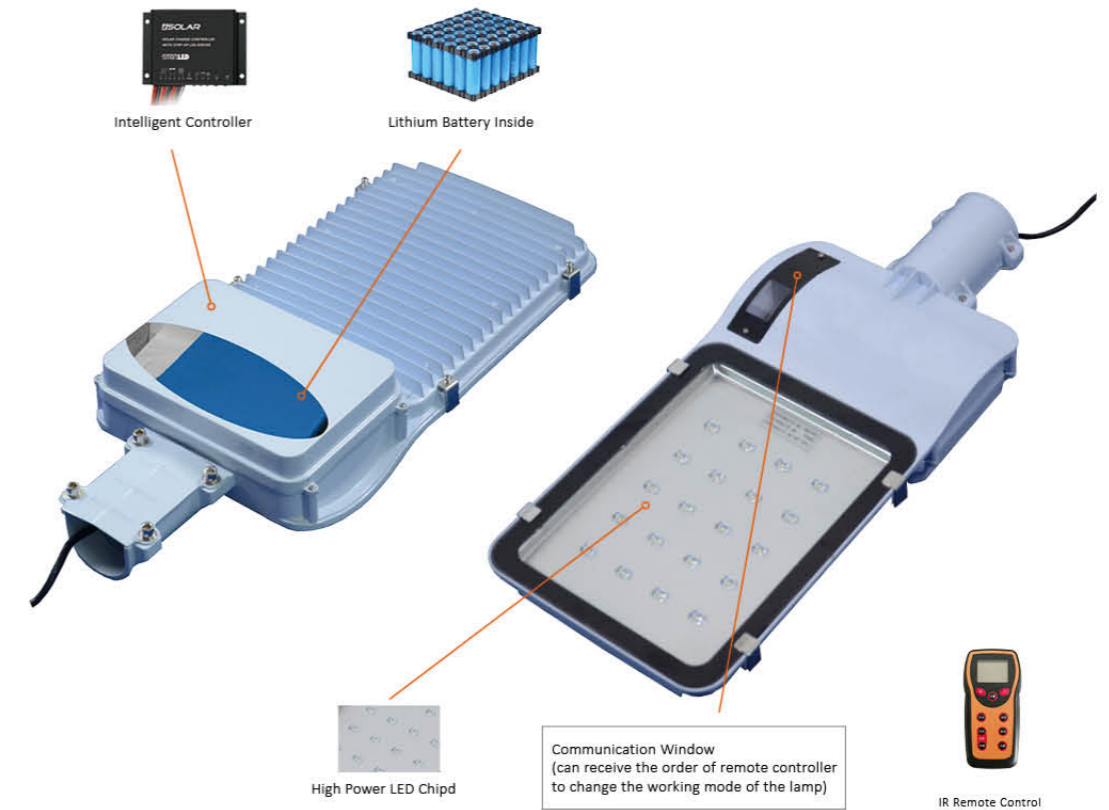

**HD038**  
Size: 510\*210\*105  
Power: 30W-60W



**HD039**  
Size: 510\*215\*80  
Power: 30W-60W



**HD040**  
Size: 550\*240\*80  
Power: 30W-80W



**HD041**  
Size: 490\*210\*95  
Power: 30W-80W



**HD042**  
Size: 490\*240\*80  
Power: 30W-60W



**HD043**  
Size: 500\*200\*80  
Power: 30W-60W

## Specifications

Product Code		HD032	HD032	HD032	HD032
Lighting Sources	Rated Power	15W	20W	30W	40W
	LED Chip	Philips LUMILEDS			
	Colour Temperature	3000-6500K			
	Lamp Efficiency	110-130 lumens/W			
	Fixture Material	Aluminium alloy			
Lithium Battery		16AH/12V	20AH/12V	30AH/12V	40AH/12V
Sensor Height (Optional)		120° Detection angle, 8 meter detection height			
Lighting Hours		8-12 hours per night			
Rainy Days Backup		2-3 days			
Discharging Time		more than 30 hours			
Ambient Temperature		-10~60°			
Lamp Adaptor		Diameter 60mm			
IP Grade		IP65			
Suggested Mounting Height		4~5Mt	4~5Mt	5~6Mt	6~7Mt
Product Size		600x280x110mm			



SSL Series



Model 产品型号	SSL001	SSL002	SSL003	SSL004
Solar Panel 太阳能板规格	18V/15W Monocrystalline Solar Panel, Grade A	18V/28W Monocrystalline Solar Panel, Grade A	18V/45W Monocrystalline Solar Panel, Grade A	18V/60W Monocrystalline Solar Panel, Grade A
LED Power 功率	8W	15W	20W	30W
Lifespan of LED 使用寿命	More Than 50,000 Hours			
Luminous Flux 光效	800lm~880lm	1500lm~1650lm	2000lm~2200lm	3000lm~3300lm
Color Temperature 色温	3000K~6500K			
Beam Angle 发光角度	70°*145° / 80°*150° / 90°			
Lithium battery 电池类型	12V, 10AH Li-ion lithium battery	12V, 16AH Li-ion lithium battery	12V, 25AH Li-ion lithium battery	12V, 35AH Li-ion lithium battery
Discharging Time 放电时长	18h (100% power), 42h (energy saving mode)			
Charing Time 充电时长	7h(AM1.5, 1000W/m <sup>2</sup> , 25°C)			
Material 灯壳材质	6063 Aluminum, PC			
Working Temperature 工作温度	-20°C~55°C			
Mounted Diameter 安装尺寸	60~89mm		76~89mm	
Mounting Height 安装高度	3~4m	4~5m	4~6m	5~7m
Mounting Space 照射范围	10~15m		15~20m	15~25m
Product Size 产品尺寸	505*325mm	740*325mm	880*325mm	1105*325mm
Packing Size 包装尺寸	570*370*110mm	780*380*190mm	920*380*190mm	1170*380*200mm
Net Weight 净重	5KG	8.7KG	11.4KG	15.5KG
Gross Weight 毛重	5.9KG	9.9KG	12.8KG	17.2KG
Control Mode 控制模式	Light, time and PIR remote control			
Package Quantity 装柜数量	800 sets/20' GP 1600 sets/40' GP	650 sets/20' GP 1300 sets/40' GP	396 sets/20' GP 792 sets/40' GP	270 sets/20' GP 550 sets/40' GP

Model	SSL005	SSL006	SSL007	SSL008	SSL009
Solar Panel   太阳能板规格	18V/70W Monocrystalline Solar Panel, Grade A	18V/80W Monocrystalline Solar Panel, Grade A	36V/130W Monocrystalline Solar Panel, Grade A	36V/130W Monocrystalline Solar Panel, Grade A	36V/180W Monocrystalline Solar Panel, Grade A
LED 功率	40W	50W	60W	80W	120W
Lifespan of LED 使用寿命	More Than 50,000 Hours				
Luminous Flux 光效	4000lm~4400m	5000lm~6600lm	8000lm~8800lm	8000lm~8800lm	12000lm~13200lm
Color Temperature 色温	3000K~6500K				
Beam Angle 发光角度	70°*145° / 80°*150° / 90°				
Lithium battery 电池类型	12V, 45AH	12V, 55AH	12V, 65AH	24V, 40AH	24V, 50AH
Discharging Time 放电时长	18h (100% power), 42h (energy saving mode)				
Charing Time 充电时长	8h(AM1.5, 1000W/m <sup>2</sup> , 25°C)	9h(AM1.5, 1000W/m <sup>2</sup> , 25°C)	10h(AM1.5, 1000W/m <sup>2</sup> , 25°C)	10h(AM1.5, 1000W/m <sup>2</sup> , 25°C)	10h(AM1.5, 1000W/m <sup>2</sup> , 25°C)
Material 灯壳材质	6063 Aluminum, PC				
Working Temperature 工作温度	-20°C~55°C				
Mounted Diameter 安装尺寸	76~89mm			89~114mm	
Mounting Height 安装高度	5~7m	6~7m	6~9m	8~10m	
Mounting Space 照射范围	15~25m	20~30m			
Product Size 产品尺寸	1075*400mm	1350*400mm	1410*565mm	2020*565mm	
Packing Size 包装尺寸	1090*460*200mm	1415*460*200mm	1470*625*265mm	2110*625*265mm	
Net Weight 净重	17.4KG	20.8KG	33KG	52KG	
Gross Weight 毛重	19.1KG	22.8KG	42.4KG	61.5KG	
Control Mode 控制模式	Light, time and PIR remote control				
Package Quantity 装柜数量	275 sets/20' GP 550 sets/40' GP	180 sets/20' GP 400 sets/40' GP	112 sets/20' GP 272 sets/40' GP	65 sets/20' GP 151 sets/40' GP	

Work Mode

25% power lighting

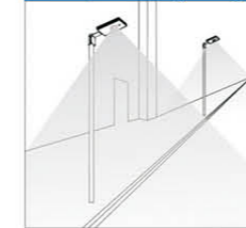

full power lighting



When nobody around the light, It works at 25% power. When people passes by, the motion sensor detedts it and the lighi will be full power lighting.







Specifications			
Product Code		SSL010	SSL011
LED Lamp	Rated Power	5W/10W	15W/20W
	LED Chip	PHILIPS Lumileds 3030 SMT	PHILIPS Lumileds 3030 SMT
	Colour Temperature	3000~6500K	3000~6500K
	Luminous flux	500/1400 LM	1500/2800 LM
	Fixture Material	Aluminium alloy	Aluminium alloy
Solar panel		10W Monocrystalline	15W/20W Monocrystalline
Battery specs		Lith 4AH/ 8AH	Lith 12AH/ 16AH
Sensor Height		Within 8Mt	Within 8Mt
Full power lighting time		>8 hours	>10 hours
Normal working days		> 3 raining days	> 3 raining days
Working Temperature		-20°C~60°C	-20°C~60°C
IP rating		IP65	IP65
Mounting Height		3~6Mt	3~6Mt
Product net weight		1.88Kg	4.9Kg
Product Size		400x210x60mm	600x300x80mm
Packing		400x350x240mm	620x360x320mm
		5 Pcs	4Pcs

Specifications			
Product Code		SSL012	SSL013
LED Lamp	Rated Power	5W/10W	15W/20W
	LED Chip	PHILIPS Lumileds 3030 SMT	PHILIPS Lumileds 3030 SMT
	Colour Temperature	3000~6500K	3000~6500K
	Luminous flux	500/1400 LM	1500/2800 LM
	Fixture Material	Aluminium alloy	Aluminium alloy
Solar panel		10W Monocrystalline	15W/20W Monocrystalline
Battery specs		Lith 4AH/ 8AH	Lith 12AH/ 16AH
Sensor Height		Within 8Mt	Within 8Mt
Full power lighting time		>8 hours	>10 hours
Normal working days		> 3 raining days	> 3 raining days
Working Temperature		-20°C~60°C	-20°C~60°C
IP rating		IP65	IP65
Mounting Height		3~6Mt	3~6Mt
Product net weight		1.88Kg	4.9Kg
Product Size		365x175x45mm	600x300x80mm
Packing		400x200x60mm	620x360x320mm
		5 Pcs	4Pcs





**Specification**

<b>Solar Panel</b>	18v/25w Monocrystalline Solar Panel, Grade A
<b>LED</b>	12w, 10x18mil Epistar Chip
<b>Lifespan of LED</b>	More Than 50,000 Hours
<b>Color Temperature</b>	3000K-6500K
<b>Beam Angle</b>	120°
<b>Battery</b>	12V, 12AH LiFePO <sub>4</sub> Lithium Battery
<b>Discharging Time</b>	18 Hours
<b>Charging Time</b>	9H (AM1.5, 1000W/m <sup>2</sup> , 25°C)
<b>Material</b>	6063 Aluminum, PC
<b>Working Temperature</b>	-25°C-55°C



SGL007  
Product Size: 465x465x425mm



SGL001  
Product Size: Φ515x720mm



SGL002  
Product Size: Φ500x660mm



SGL003  
Product Size: Φ540x620mm

**SGL008**

Product Size: Φ510x175mm

产品尺寸 Product Size

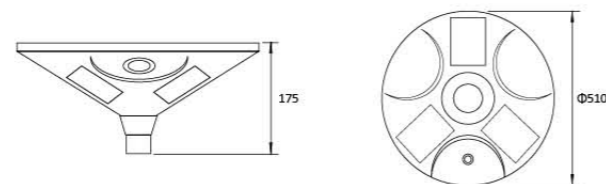

照明模式 Lighting Mode

当物体进入感应范围, 达到 100% 的亮度;  
当物体离开感应范围, 将在 30 秒自动调  
节为节能模式  
DIM light with PIR

应用范围 Application

街道, 庭院, 道路, 公共广场, 停车场  
Street, Courtyard, Roadway,  
Public square, Parking lot



SGL004  
Product Size: Φ500x550mm



SGL005  
Product Size: Φ510x565mm



SGL006  
Product Size: Φ510x600mm





SLL001 (H=800mm)



SLL002 (H=1000mm)



SLL003 (H=760mm)



SLL004 (H=800mm)



SLL008 (H=800mm)



SLL009 (H=1000mm)



SLL010 (H=800mm)



SLL005 (H=800mm)



SLL006 (H=800mm)



SLL007 (H=860mm)



SLL011 (H=800mm)



SLL012 (H=800mm)



SLL013 (H=745mm)



SLL014 (H=800mm)

### Specification

<b>Solar Panel</b>	9v/5.5w Monocrystalline Solar Panel, Grade A
<b>LED</b>	3.5w, 10x18mil Epistar Chip
<b>Lifespan of LED</b>	More Than 50,000 Hours
<b>Color Temperature</b>	3000K-6500K
<b>Beam Angle</b>	120°
<b>Battery</b>	6.4V, 4.5AH LiFePO <sub>4</sub> Lithium Battery
<b>Discharging Time</b>	23 Hours
<b>Charging Time</b>	6H (AM1.5, 1000W/m <sup>2</sup> , 25°C)
<b>Material</b>	6063 Aluminum, PC
<b>Working Temperature</b>	-25°C-55°C



SLL015 (H=240mm)



SLL016 (H=325mm)



SLL017 (H=335mm)



SLL018 (H=400mm)